

**THANK YOU FOR DOWNLOADING THIS MANUAL. I HOPE IT HELPS YOU RESOLVE ANY ISSUES YOU HAVE HAD WITH YOUR GAME.**

**THIS MANUAL WAS PURCHASED, AND SCANNED BY BASEMENT ARCADE ASSOCIATES, [WWW.BASEMENTARCADE.COM](http://WWW.BASEMENTARCADE.COM) AND IS OFFERED FOR FREE DOWNLOAD AT OUR SITE.**

**THIS PDF IS NOT TO BE DISTRIBUTED ON ANY COLLECTION CD / DVD, NOR IS TO BE LINKED TO VIA ANY OTHER INTERNET SITE WITHOUT PERMISSION FROM US. LIKEWISE IT IS NOT TO BE DISTRIBUTED FROM ANY OTHER SITE WITHOUT OUR PERMISSION.**

**ABIDING BY THESE REQUESTS, WILL INSURE THE CONTINUING SUPPORT OF NEW MANUALS ADDED TO OUR SITE.**

**ALL ORIGINAL COPYRIGHTS HELD BY THEIR ORIGINAL OWNERS, THIS PDF COPYRIGHTED BASEMENT ARCADE ASSOCIATES.**

**--MARK--**

# DONKEY KONG™

## OPERATION MANUAL

**MODEL NO: TKG4-UP**

2 P.C. BOARDS TYPE



**Nintendo™**

WARNING

This equipment generates, uses and can radiate radio frequency energy and if not installed and used in accordance with the instructions manual, may cause interference to radio communications. As temporarily permitted by regulation it has not been tested for compliance with the limits for Class A computing devices pursuant to Subpart J of Part 15 of FCC Rules, which are designed to provide reasonable protection against such interference. Operation of this equipment in a residential area is likely to cause interference in which case the user at his own expense will be required to take whatever measures may be required to correct the interference.

C O N T E N T S

=====

1. CAUTIONS	.....	1
2. SPECIFICATIONS	.....	2
3. INSTALLATION OF THE MACHINE		
(1) Cautions on installation	.....	3
(2) Earthing of machine	.....	3
4. MAINTENANCE AND INSPECTION		
(1) Dismounting of front screen	.....	4
(2) Dismounting of operation panel	.....	4
5. POINTS AND METHODS OF ADJUSTMENT		
(1) CPU P.C.Board	.....	5
(2) Adjustment of Semi-Fixed Resistors	.....	6
(3) Video Monitor	.....	7
6. WIRING AND CONNECTION	.....	8
7. NAME OF EACH PART		
(1) Body	.....	9
(2) Operation Panel Assembly	.....	11
8. PART LIST	.....	12

C A U T I O N S

=====

1. P.C.Board should not be exposed direct to the sun. Direct sunshine is very harmful to LSI(memory element).
2. P.C.Board to be stored or transported should be wrapped by a conductive pouch or aluminum foil, because LSI and IC used in the machine are semiconductor integrated circuits of which basic element is MOS-FET.
3. When images on the Video Monitor screen are disturbed by powerful noise or other electrical causes, turn the main power off once and then on again.

## 2. SPECIFICATIONS

Power Consumption	:	118W
Size	:	600(W) × 850(D) × 1700(H)mm.
Weight	:	100 Kgs.
Number of Player	:	1 or 2 person(s)
Number of Jumpman	:	3 ~ 6 (Adjustable)
Accessories	:	Operation Manual : 1 copy
		Key for Back Door : 2 pcs.
		Key for Coin Box Door : 2 pcs.
		Fuse : 4 pcs.
		100~120V : 5A × 1, 4A × 2, 0.3A × 1
		220~240V : 4A × 2, 3A × 1, 0.3A × 1

NOTE: Specifications are subject to change for improvement without notice.

### 3-1 Cautions on installation

- (1) The power cord of the machine should not be connected to a wall outlet together with large load unit(s) such as motor, cooler, etc.
- (2) Turn the power off before setting and removing the P.C. Board and connectors. Carefully handle them.
- (3) Do not touch IC, LSI and other electronic parts on P.C. Board. Do not use a tester or the like on them. (They may be damaged by the inner voltage of the instruments.)
- (4) When exchanging a fuse, use a new one of the prescribed capacity.
- (5) The machine should be installed where it is not hot, keeping away from a heating appliance and direct sunshine.
- (6) The machine should be installed where it is not wet and dusty.
- (7) Do not touch the inside of the video monitor which has high tension units. Inform service station, if necessary.

### 3-2 Earthing of machine

- (1) When the machine is installed in a wet place, it should be grounded to avoid accident by an electric shock.
  - a) Connect an earthing wire to the earthing terminal of the machine.
  - b) The opposite end of the earthing wire should be connected to an earthing bar which is firmly inserted into the ground.
- (2) Cautions
  - a) Do not connect the earthing wire to a water pipe, because polyvinyl-chloride pipes are sometimes used in the water lines and, if so, the electronic continuity is cut at the points.
  - b) Do not connect the earthing wire to the gas pipe absolutely. That is very dangerous.

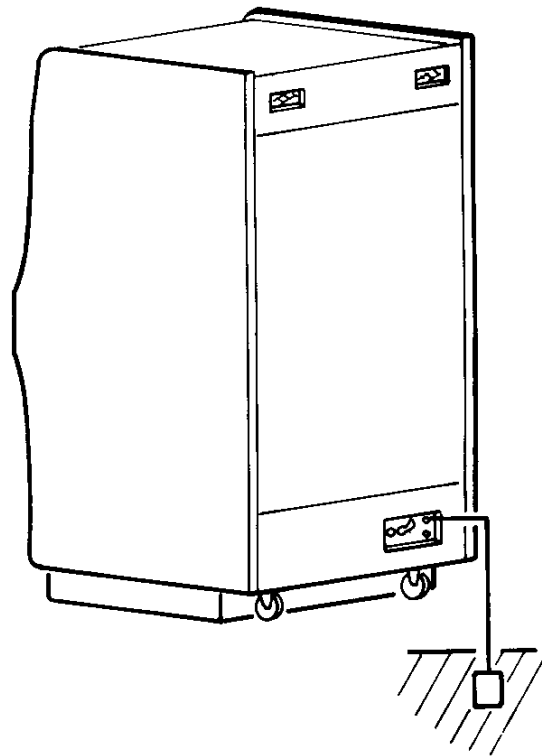

#### 4. MAINTENANCE AND INSPECTION

##### 4-1 Dismounting of front screen

Opening the back door, pull the front screen clamp which is mounted under the top plate. Pull the front screen upward while pushing and then pull toward you.

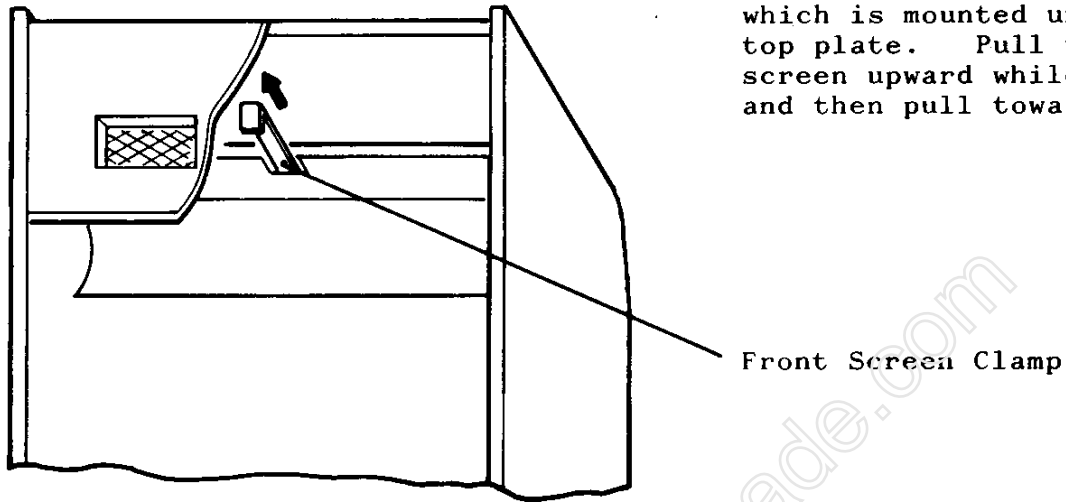

##### 4-2 Dismounting of operation panel

To dismount the operation panel for maintenance or inspection of the Control Unit or Micro Switch, open the front door and unfasten the fastener.

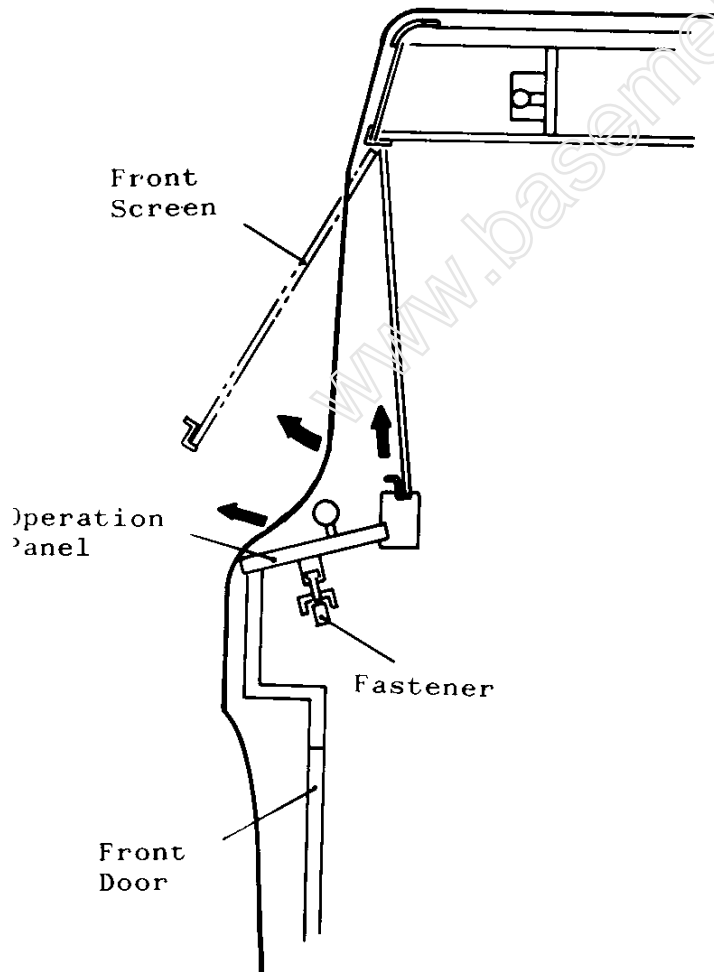

## 5. POINTS AND METHODS OF ADJUSTMENT

### 5-1 CPU P.C.Board

The number of Jumpman, score level, the number of coin and type of machine can be set with the switches on CPU P.C.Board according to the diagram below.

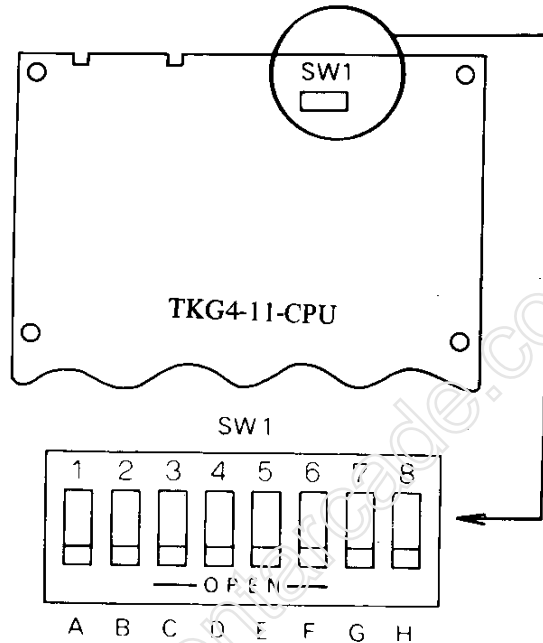

	A	B	C	D	E	F	G	H
<b>Number of Jumpman</b>								
3	OFF	OFF						
4	ON	OFF						
5	OFF	ON						
6	ON	ON						
<b>Score Level for extra Jumpman</b>								
7,000 points			OFF	OFF				
10,000 points			ON	OFF				
15,000 points			OFF	ON				
20,000 points			ON	ON				
<b>Coinage</b>								
1 coin /1 play					OFF	OFF	OFF	
1 coin /2 plays					OFF	ON	OFF	
1 coin /3 plays					OFF	OFF	ON	
1 coin /4 plays					OFF	ON	ON	
2 coins/1 play					ON	OFF	OFF	
3 coins/1 play					ON	ON	OFF	
4 coins/1 play					ON	OFF	ON	
5 coins/1 play					ON	ON	ON	
<b>Table/Upright</b>								
Table								OFF
Upright								ON

NOTE : Keep the switch H always at the ON position.





## 5-2 Adjustment of Semi-Fixed Resistors

### VIDEO P.C. Board

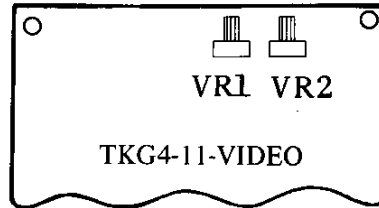
Semi-fixed resistors, VR1 and VR2 on VIDEO P.C. Board are used to adjust video monitor screen.



VIDEO P.C. Board

VR1	50K $\Omega$ 1/3W top type white knob		Turn right to move image downward.
VR2	50K $\Omega$ 1/3W top type white knob		Turn right to move image leftward

### CPU P. C. Board

Semi-fixed resistor, VR2 on CPU P.C. Board is used to adjust sound balance.

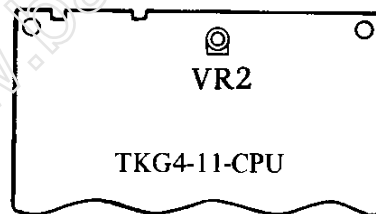

CPU P.C. Board

VR2	10K $\Omega$ 1/5W plain type white knob	Balance of effective sound
-----	---	----------------------------

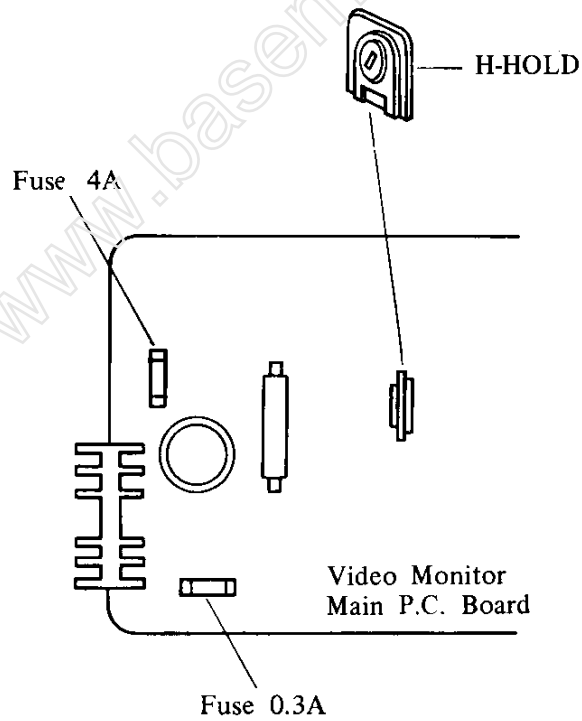
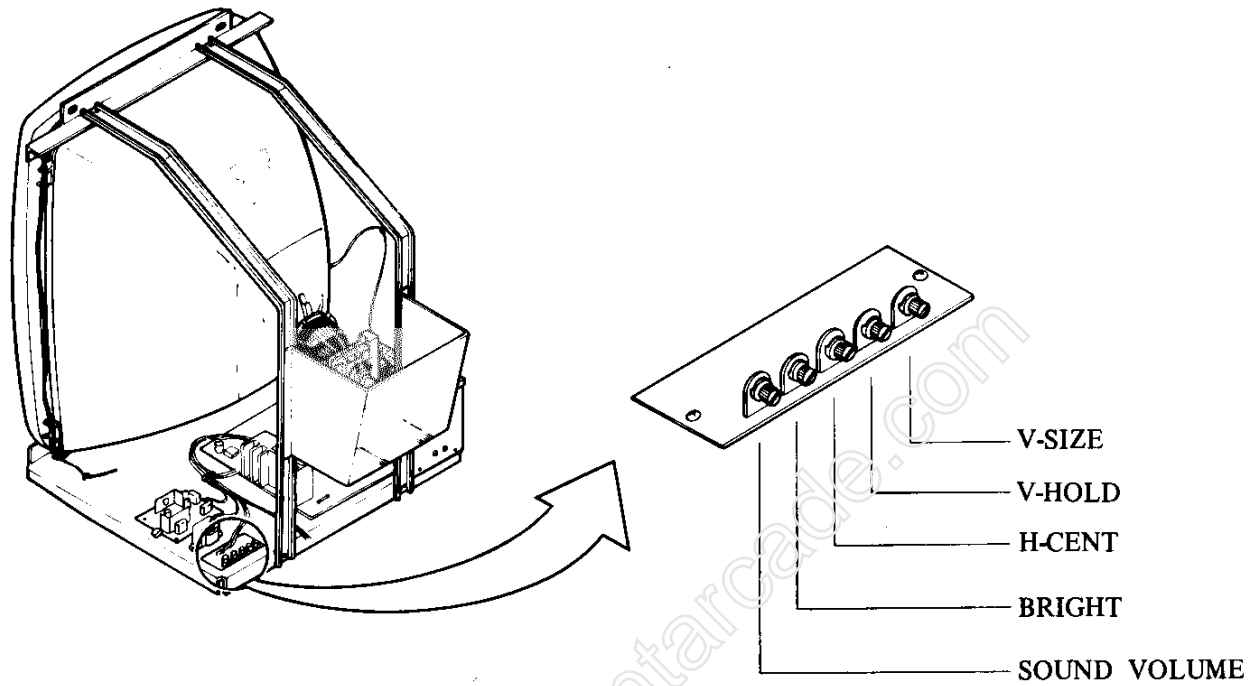

NOTE : Do not touch the inside of the Video Monitor in which many parts are supplied with high tension.



7. NAME OF EACH PART

(1) Body

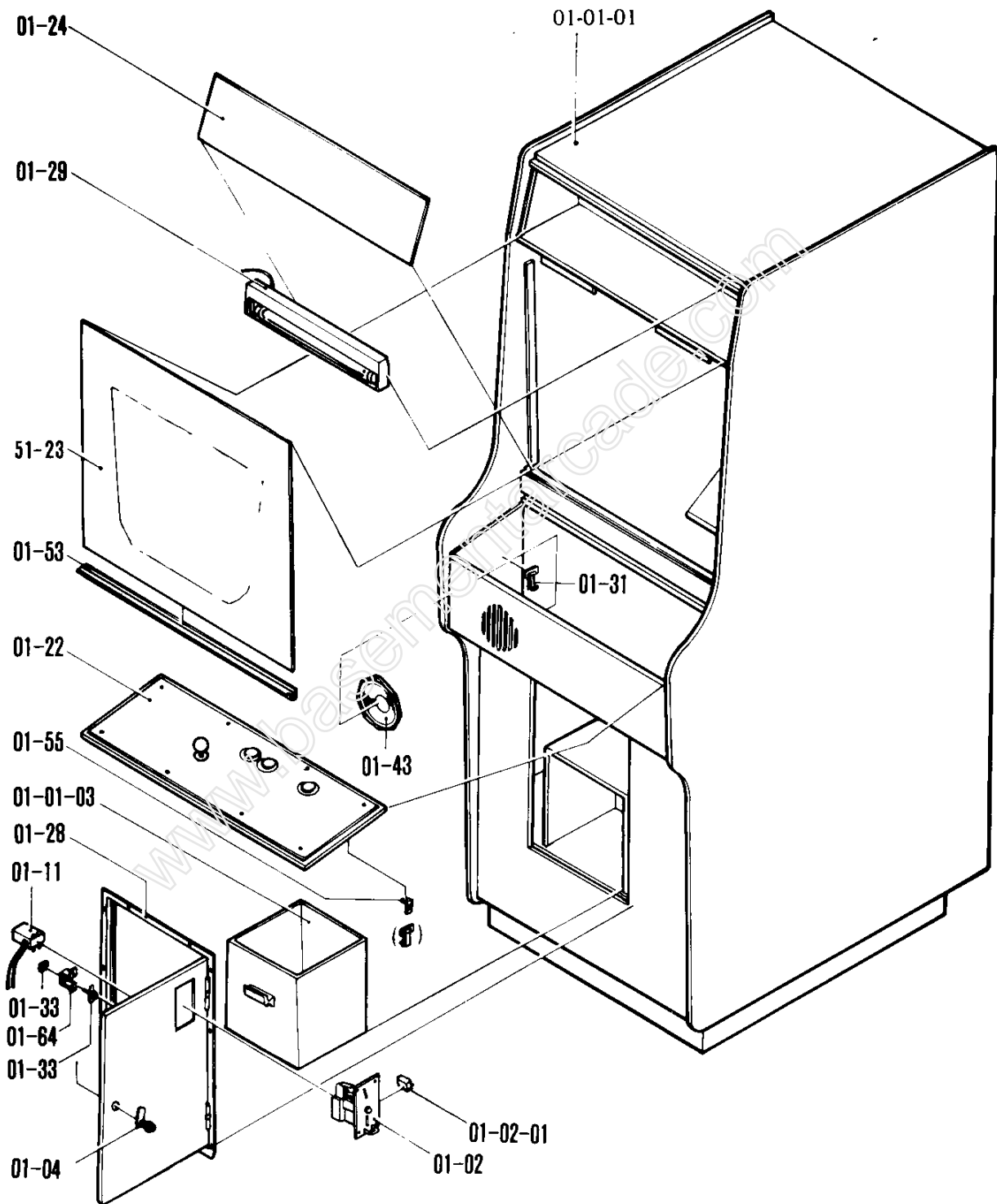

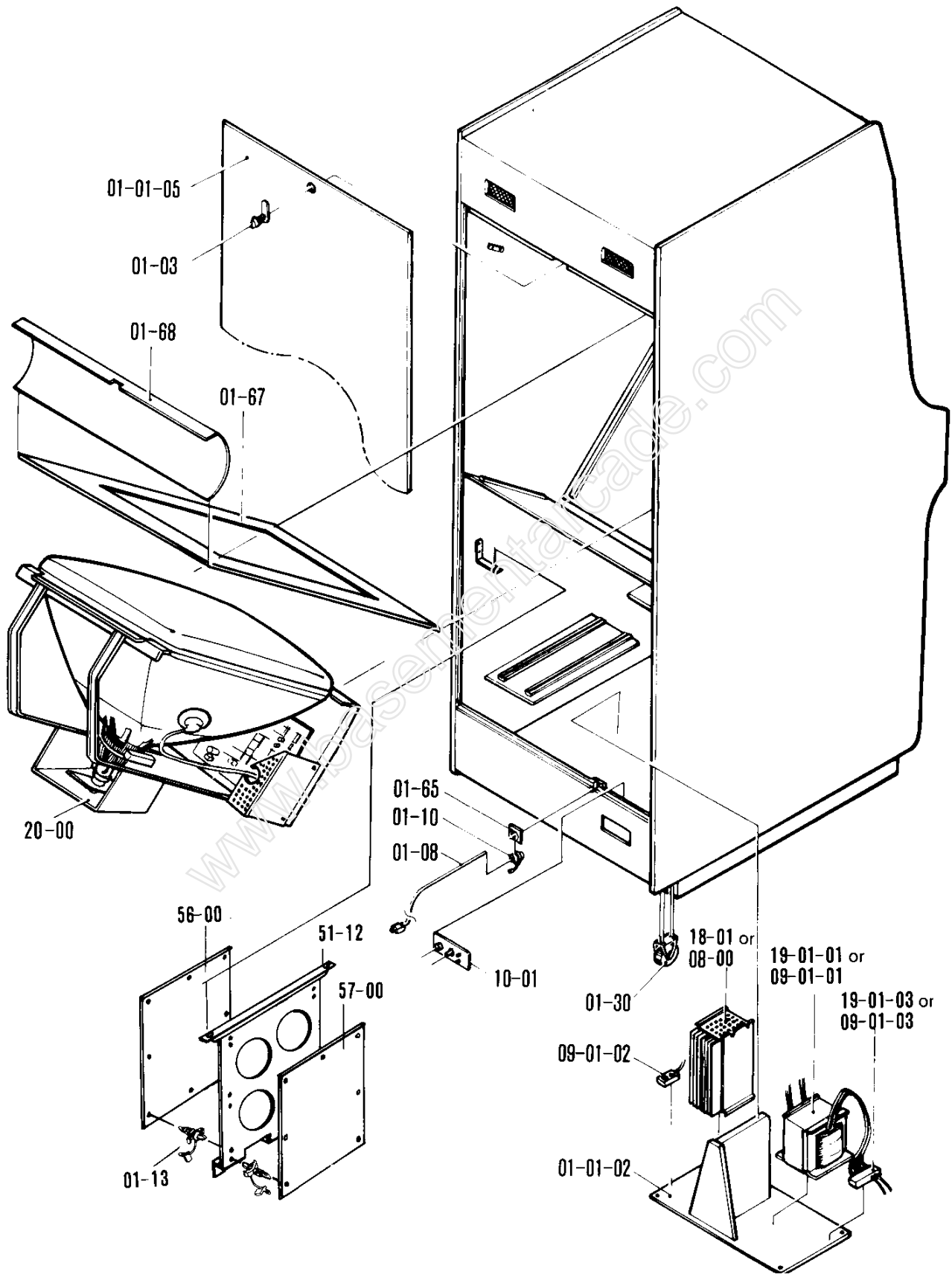

(2) Operation Panel Assembly

23-50 4 Way Control Lever A'ssy

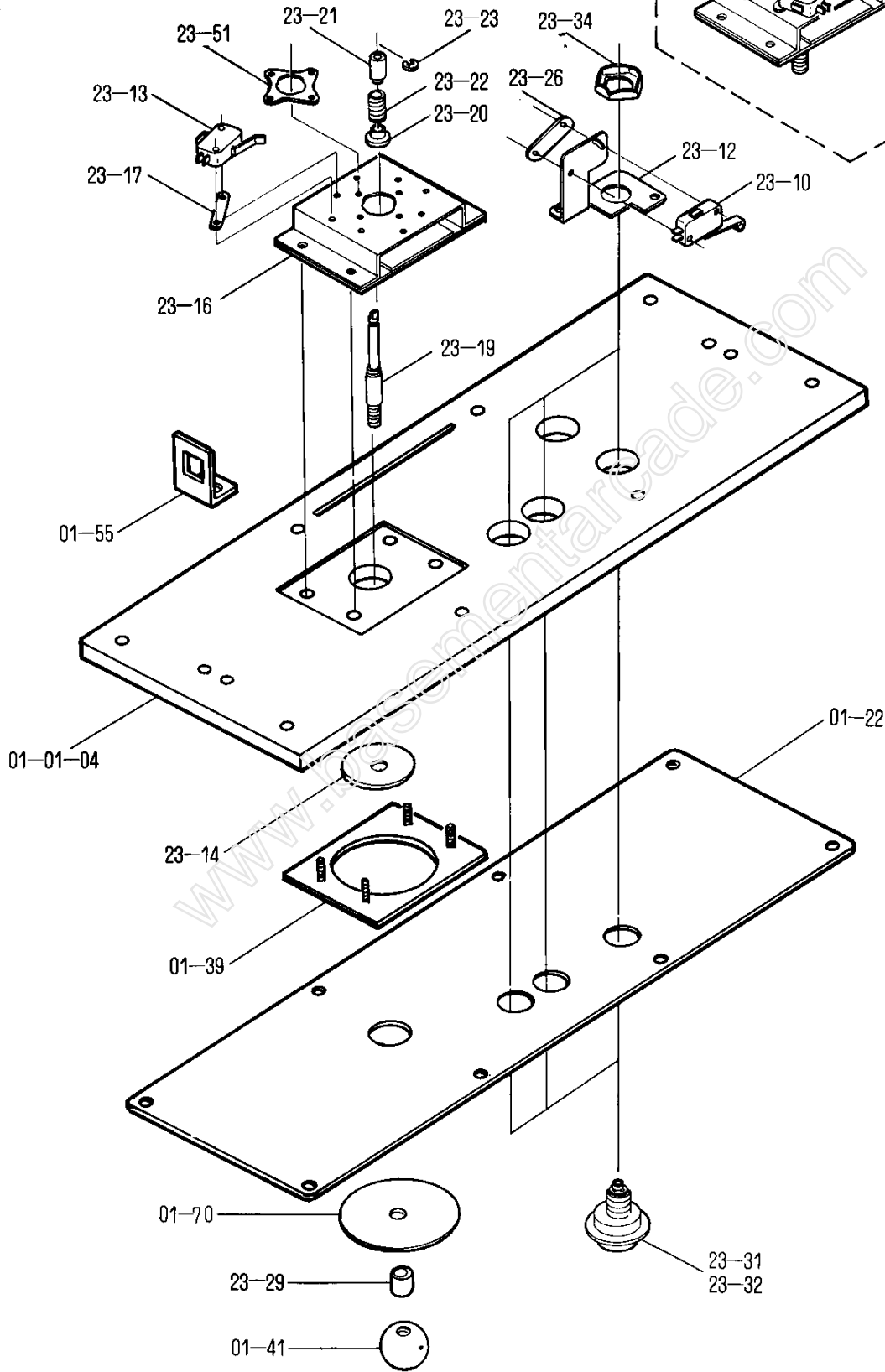

## 8. PARTS LIST

### 1. TKG4-Body

No.	Name of Parts	Q'ty	Remarks	FOB Japan per pc.
TKGU-01-01-01	Body	1		
TKGU-01-01-02	Transformer Base	1		
TKGU-01-01-03	Cash Box	1		
TKGU-01-01-04	Control Lever Ass'y Base	1		
TKGU-01-01-05	Back Door	1		
TKGU-01-02	Coin Selector	1	T	
TKGU-01-02-01	Coin Switch	1	T	
TKGU-01-03	Back Door Lock	1		
TKGU-01-04	Front Door Lock	1		
TKGU-01-08	Power Cord	1		
TKGU-01-10	Strain Relief Bushing	1	T	
TKGU-01-11	Game Counter	1	T	
TKGU-51-12	TKG4 P.C.Board Mounting Bracket	1		
TKGU-01-13	P.C.Board Support	16		
TKGU-01-22	Operation Panel	1		
TKGU-51-23	Front Screen	1		
TKGU-01-24	Name Plate	1		
TKGU-01-28	Front Door Ass'y	1		
TKGU-01-29	Fluorescent Lamp Ass'y	1		
TKGU-01-30	Caster	2		
TKGU-01-31	Operation Panel Ass'y Fastener (A)	2		
TKGU-01-33	Service Switch	1	T	
TKGU-01-39	Control Lever Ass'y Mounting Plate	1		
TKGU-01-41	Control Lever Knob	1		
TKGU-01-43	Speaker	1		
TKGU-01-53	Front Screen Frame (Lower)	1		
TKGU-01-55	Operation Panel Ass'y Fastener (B)	2		
TKGU-01-64	Service Switch Bracket	1		
TKGU-01-65	Strain Relief Bushing Plate	1		
TKGU-01-67	Blind Cardboard (Large)	1		
TKGU-01-68	Blind Cardboard (Small)	1		
TKGU-01-70	Control Knob Plate	1		
TKGU-56-00	VIDEO P.C.Board	1	(TKG4-11-VIDEO)	
TKGU-57-00	CPU P.C.Board	1	(TKG4-11-CPU)	
TKGU-08-00	(PP-7A) Power P.C.Board	1	T	

No.	Name of Parts	Q'ty	Remarks	FOB Japan per pc.
TKGU-18-01	(PP-7B) Power P.C.Board	1	T	
TKGU-09-01-01	(PT-8A) Power Transformer	1		
TKGU-19-01-01	(PT-821B) Power Transformer	1		
TKGU-09-01-02	2P Table Tap	1		
TKGU-09-01-03	Terminal Block	1	(Sexipolar)	
TKGU-19-01-03	Terminal Block	1	(Quadrupolar)	
TKGU-10-01	Power Switch Ass'y	1		
TKGU-13-01	10P CLK Harness Connector	1	T	
TKGU-13-02	2P Counter Harness Connector	1		
TKGU-13-03	9P CPU Harness Connector	1	T	
TKGU-13-04	3P Coin Harness Connector	1		
TKGU-13-05	5P Service Harness Connector	1		
TKGU-13-06	2P Speaker TV Harness Connector	1		
TKGU-13-07	4P-750 Audio Harness Connector	1	T	
TKGU-13-10	9P Main Switch Harness Connector	1		
TKGU-13-11	17P Junction Harness Connector	1		
TKGU-13-12	50P Flat Cable	2	T	
TKGU-13-17	2P Speaker Harness Connector	1		
TKGU-13-28	3P Junction Harness Connector	1		
TKGU-13-29	4P Main Switch Harness Connector	1		
TKGU-13-31	6P-1000 Video Harness Connector	1		
TKGU-20-00	Video Monitor	1	(20-5F)	
TKGU-23-10	Micro Switch	3		
TKGU-23-12	Switch Button Bracket	3		
TKGU-23-13	Control Switch	4	T	
TKGU-23-14	Blind Plate	1	T	
TKGU-23-16	Bearing Bracket	1	T	
TKGU-23-17	Switch Spacer	4	T	
TKGU-23-19	Schaft	1	T	
TKGU-23-20	Spring Stopper	1	T	
TKGU-23-21	Switch Collar	1	T	
TKGU-23-22	Lever Spring	1	T	
TKGU-23-23	E Ring 4	1	T	
TKGU-23-26	Nut Plate	3		
TKGU-23-29	Control Knob Collar	1	T	
TKGU-23-31	Switch Button Ass'y (Blue)	2		
TKGU-23-32	Switch Button Ass'y (Orange)	1		
TKGU-23-34	Pal Nut	3		



No.	Name of Parts	Q'ty	Remarks	FOB Japan per pc.
TKGU-23-50	4 Way Control Lever Ass'y	1	T	
TKGU-23-51	4 Way Guide Plate	1	T	

www.basementarcade.com

## 2. VIDEO P.C.Board

No.	Name of Parts	Q'ty	Remarks	FOB Japan per pc.
TKG-56-00	VIDEO P.C.Board	1	Complete Set (TKG4-11-VIDEO)	
TKG-56-01	IC SN74LS00	2	Quadruple 2 - Input Positive NAND Gates	
TKG-56-02	IC SN74LS02	3	Quadruple 2 - Input Positive Nor Gates	
TKG-56-03	IC SN74LS04	6	Hex Inverters	
TKG-56-04	IC SN74LS08	1	Quadruple 2 - Input AND Gate	
TKG-56-05	IC SN74LS10	1	Tri 3 Input NAND Gate	
TKG-56-06	IC SN74LS20	4	Dual 4 - Input Positive NAND Gate	
TKG-56-07	IC SN74LS30	1	8 - Input Positive NAND Gate	
TKG-56-08	IC SN74LS32	1	Quadruple 2 - Input Positive or Gate	
TKG-56-09	IC SN74LS74	4	Dual D-Type Edge-Triggered Flip-Flop w/Set and Reset	
TKG-56-10	IC SN74LS86	7	Quadruple 2 - Input Executive OR Gate	
TKG-56-11	IC SN74LS109	1	Dual J-K Positive Edge-Triggered Flip-Flops with Preset and Clear	
TKG-56-12	IC SN74LS123	2	Dual Retriggerable Single Shot	
TKG-56-13	IC SN74LS139	1	Dual 2- to 4-Line Decoder/Demultiplexer	
TKG-56-14	IC SN74LS157	14	Quadruple 2-Line to 1-Line Data	
TKG-56-15	IC SN74LS161	4	Synchronous Presettable 4-Bit Binary Counter w/Direct Reset	
TKG-56-16	IC SN74LS163	2	4-Bit Binary Counter with Synchronous clear	
TKG-56-17	IC SN74LS174	1	Hex D-Type Flip-Flop w/Reset RAM	
TKG-56-18	IC SN74LS175	2	Quadruple D-Type Flip-Flop w/Reset	
TKG-56-19	IC SN74LS245	2	Octal 3-State Bus Transceivers	
TKG-56-20	IC SN74LS273	4	Octal D-FFS	
TKG-56-21	IC SN74LS283	8	4 Bit Binary Full Adder	
TKG-56-22	IC SN74LS299	6	8 Bit Bidirectional Universal Shift/Storage	
TKG-56-23	IC SN74LS367	2	Hex Bus Driver w/3 State Output	
TKG-56-24	IC SN74LS373	2	Octal 3-State D-Latches	
TKG-56-25	IC SN74LS377	1	Octal D-Type Flip-Flops	
TKG-56-26	IC SN74S161	3	Schotkey 4-Bit Binary Counter with Direct Clear	
TKG-56-27	IC MB10105	1	Triple 2-3-2- Input OR/NOR Gates	
TKG-56-28	IC MB10116	1	Triple Line Receivers	
TKG-56-29	IC MB10124	4	Quadruple TTL-to-ECL Translators	
TKG-56-30	IC MB10125	3	Quadruple ECL-to-TTL Translators	

No	Name of Parts	Q'ty	Remarks	FOB Japan per pc.
TKG-56-31	IC MB10136	1	Universal Hexadecimal Counter	
TKG-56-32	IC 2716	6	2048 x 8 Bit EP-ROM	
TKG-56-33	IC MB7074	2	ECL-RAM (MBM10422) with Radiator Fin	
TKG-56-34	IC MB93419	1	64 x 9 Bipolar RAM	
TKG-56-35	IC MB8114	2	1024 x 4-Bit Static MOS RAM	
TKG-56-36	IC MB8148L55	2	1024 x 4-Bit Static RAM	
TKG-56-37	IC 24S10	1	256 x 4-Bit Bipolar P-ROM	
TKG-56-38	Resistor Array	4	RNSA-09P-551J 8-device 510 $\Omega$	
TKG-56-39	Resistor Array	1	RNSA-09P-102J 8-device 1k $\Omega$	
TKG-56-40	Variable Resistor	2	50k $\Omega$ 1/3W	
TKG-56-41	Resistor (Carbon)	2	10k $\Omega$ 1/4W $\pm$ 5%	
TKG-56-42	Resistor (Carbon)	12	510 $\Omega$ 1/4W $\pm$ 5%	
TKG-56-43	Resistor (Carbon)	2	15k $\Omega$ 1/4W $\pm$ 5%	
TKG-56-44	Resistor (Carbon)	2	2.2k $\Omega$ 1/4W $\pm$ 5%	
TKG-56-45	Resistor (Carbon)	2	4.7k $\Omega$ 1/4W $\pm$ 5%	
TKG-56-46	Resistor (Carbon)	1	22k $\Omega$ 1/4W $\pm$ 5%	
TKG-56-47	Resistor (Carbon)	1	27k $\Omega$ 1/4W $\pm$ 5%	
TKG-56-48	Resistor (Carbon)	23	1k $\Omega$ 1/4W $\pm$ 5%	
TKG-56-49	Electrolytic Capacitor	2	220 $\mu$ F 16V	
TKG-56-50	Electrolytic Capacitor	2	1 $\mu$ F 50V	
TKG-56-51	Ceramic Capacitor	1	47pF 50V	
TKG-56-52	Ceramic Capacitor	128	0.01 $\mu$ F 50V	
TKG-56-53	Ceramic Capacitor	1	33pF 50V	
TKG-56-54	Ceramic Capacitor	2	10pF 50V	
TKG-56-55	Ceramic Capacitor	1	220pF 50V	
TKG-56-56	Ceramic Capacitor	1	68pF 50V	
TKG-56-57	Polyester Film Capacitor	1	1000pF 50V (102kz)	
TKG-56-58	Polyester Film Capacitor	1	0.1 $\mu$ F 50V	
TKG-56-59	Polyester Film Capacitor	1	0.022 $\mu$ F 50V	
TKG-56-60	Transistor	2	2SC1215-R/S/T	
TKG-56-61	Crystal Oscillator	1	61.44MHz (HC-18U)	

3. CPU P.C.Board

No.	Name of Parts	Q'ty	Remarks	FOB Japan per pc.
TKG-57-00	CPU P.C.Board	1	Complete Set (TKG4-11-CPU)	
TKG-57-01	IC SN74LS00	2	Quadruple 2 - Input Positive NAND Gates	
TKG-57-02	IC SN74LS02	2	Quadruple 2 - Input Positive NOR Gate	
TKG-57-03	IC SN74LS04	5	Hex Inverters	
TKG-57-04	IC SN74LS05	1	Hex Inverter Open Collector	
TKG-57-05	IC SN74LS08	1	Quadruple 2 - Input AND Gates	
TKG-57-06	IC SN74LS32	1	Quadruple 2 - Input Positive OR Gate	
TKG-57-07	IC SN74LS74	2	Dual D-Type Edge-Triggered Flip-Flop w/Set and Reset	
TKG-57-08	IC SN74LS75	2	Quadruple Bistable Latch	
TKG-57-09	IC SN74LS86	1	Quadruple 2 - Input Exclusive OR Gate	
TKG-57-10	IC SN74LS123	1	Dual Retriggerable Single Shot	
TKG-57-11	IC SN74LS125	1	Quadruple 3 State Bus Buffers	
TKG-57-12	IC SN74LS132	1	Quadruple 2 - Input NAND Schmit Triggers	
TKG-57-13	IC SN74LS138	6	3- to 8-Line Decoder/Demultiplexer	
TKG-57-14	IC SN74LS139	1	Dual 2- to 4-Line Decoder/Demultiplexer	
TKG-57-15	IC SN74LS161	1	Synchronous Presettable 4-Bit Binary Counter w/Direct Reset	
TKG-57-16	IC SN74LS164	3	8-Bit Serial-In Parallel-Out Shift Register	
TKG-57-17	IC SN74LS174	2	Hex D-Type Flip-Flop w/Reset RAM	
TKG-57-18	IC SN74LS175	1	Quadruple D-Type Flip-Flop w/Reset	
TKG-57-19	IC SN74LS240	4	Octal Buffer/Line Driver/Line Receiver w/3-State	
TKG-57-20	IC SN74LS245	1	Octal 3-State Bus Transceivers	
TKG-57-21	IC SN74LS259	2	8-Bit Addressable Latches	
TKG-57-22	IC SN74LS367	6	Hex Bus Driver W/3 State Output	
TKG-57-23	IC SN74LS373	2	Octal 3-State D-latches	
TKG-57-24	IC MB8114	6	1024 x 4-Bit Static MOS RAM	
TKG-57-25	IC 2532	4	4096 x 8-Bit EP ROM	
TKG-57-26	IC Z80A	1	8-Bit Microprocessor	
TKG-57-27	IC 24S10	2	Bipolar ROM 256 x 4-Bit	
TKG-57-28	IC 8257-5	1	DMA Controller	
TKG-57-29	IC 2716	2	2048 x 8-Bit EP ROM	
TKG-57-30	IC MB8884	1	8-Bit Microprocessor	

No.	Name of Parts	Q'ty	Remarks	FOB Japan per pc.
TKG-57-31	IC MB3614	1	Lower Power Quadruple Operational Amplifiers	
TKG-57-32	IC NE556	1	Dual Timer	
TKG-57-33	IC DAC08CQ	1	8-Bit Digital-to-Analog Converter	
TKG-57-34	IC CD4049UB	1	Hex Buffer/Converter (Inverting)	
TKG-57-35	Transistor	7	2SC1815	
TKG-57-36	Transistor	1	2SC1384-R	
TKG-57-37	Transistor	4	2SC828-P/Q	
TKG-57-38	Transistor	2	2SA564-P/Q/R	
TKG-57-39	Diode	9	ISS53	
TKG-57-40	Diode	4	IS953	
TKG-57-41	Diode	1	W03B	
TKG-57-42	Dip Switch	1	B-8A	
TKG-57-43	Aluminium Electrolytic Capacitor	2	470 $\mu$ F 16V	
TKG-57-44	Electrolytic Capacitor	1	220 $\mu$ F 25V	
TKG-57-45	Electrolytic Capacitor	2	33 $\mu$ F 16V	
TKG-57-46	Electrolytic Capacitor	6	1 $\mu$ F 50V	
TKG-57-47	Electrolytic Capacitor	2	4.7 $\mu$ F 25V	
TKG-57-48	Electrolytic Capacitor	4	3.3 $\mu$ F 50V	
TKG-57-49	Electrolytic Capacitor	15	10 $\mu$ F 16V	
TKG-57-50	Electrolytic Capacitor	2	100 $\mu$ F 16V	
TKG-57-51	Electrolytic Capacitor	1	47 $\mu$ F 25V	
TKG-57-53	Ceramic Capacitor	3	0.068 $\mu$ F 25V	
TKG-57-54	Ceramic Capacitor	86	0.01 $\mu$ F 50V	
TKG-57-55	Ceramic Capacitor	1	0.022 $\mu$ F 25V	
TKG-57-56	Ceramic Capacitor	2	22pF 50V	
TKG-57-57	Ceramic Capacitor	1	0.001 $\mu$ F 25V	
TKG-57-58	Ceramic Capacitor	1	0.1 $\mu$ F 50V	
TKG-57-59	Polyester Film Capacitor	2	0.047 $\mu$ F 50V	
TKG-57-60	Polyester Film Capacitor	1	0.033 $\mu$ F 50V	
TKG-57-61	Tantalum Capacitor	3	10 $\mu$ F 16V	
TKG-57-62	Variable Resistor	1	10k $\Omega$ 1/5W (RVA0911V-306-7B103)	
TKG-57-63	Series Resistor Array	3	1k $\Omega$ PNSA-09P-102J	
TKG-57-64	Parallel Resistor Array	6	68 $\Omega$ PNSB-08P-680J	
TKG-57-65	Series Resistor Array	1	4.7k $\Omega$ PNSB-09P-472J	
TKG-57-66	Resistor (Carbon)	6	47k $\Omega$ 1/4W $\pm$ 5%	
TKG-57-67	Resistor (Carbon)	2	5.1k $\Omega$ 1/4W $\pm$ 5%	
TKG-57-68	Resistor (Carbon)	3	2k $\Omega$ 1/4W $\pm$ 5%	

No.	Name of Parts	Q'ty	Remarks	FOB Japan per pc.
TKG -57-69	Resistor (Carbon)	1	750Ω 1/4W ±5%	
TKG -57-70	Resistor (Carbon)	8	4.7kΩ 1/4W ±5%	
TKG -57-71	Resistor (Carbon)	14	10kΩ 1/4W ±5%	
TKG -57-72	Resistor (Carbon)	3	100kΩ 1/4W ±5%	
TKG -57-73	Resistor (Carbon)	2	43kΩ 1/4W ±5%	
TKG -57-74	Resistor (Carbon)	16	1kΩ 1/4W ±5%	
TKG -57-75	Resistor (Carbon)	5	5.6kΩ 1/4W ±5%	
TKG -57-76	Resistor (Carbon)	1	120Ω 1/4W ±5%	
TKG -57-77	Resistor (Carbon)	2	150Ω 1/4W ±5%	
TKG -57-78	Resistor (Carbon)	1	18kΩ 1/4W ±5%	
TKG -57-79	Resistor (Carbon)	1	3.3MΩ 1/4W ±5%	
TKG -57-80	Resistor (Carbon)	2	27kΩ 1/4W ±5%	
TKG -57-81	Resistor (Carbon)	2	1.2kΩ 1/4W ±5%	
TKG -57-82	Resistor (Carbon)	1	12kΩ 1/4W ±5%	
TKG -57-83	Resistor (Carbon)	1	4.3kΩ 1/4W ±5%	
TKG -57-84	Resistor (Carbon)	5	68Ω 1/4W ±5%	
TKG -57-85	Resistor (Carbon)	7	330Ω 1/4W ±5%	
TKG -57-86	Resistor (Carbon)	2	33kΩ 1/4W ±5%	
TKG -57-87	Resistor (Carbon)	4	220Ω 1/4W ±5%	
TKG -57-88	Resistor (Carbon)	5	470Ω 1/4W ±5%	
TKG -57-89	Resistor (Carbon)	1	680Ω 1/4W ±5%	
TKG -57-90	Resistor (Carbon)	3	100Ω 1/4W ±5%	
TKG -57-91	Resistor (Carbon)	1	200Ω 1/4W ±5%	
TKG -57-92	Crystal Oscillator	1	HC-18U-182 (6.000MHz)	