

MIDWAY

NOVEMBER 1998

16-40069-101

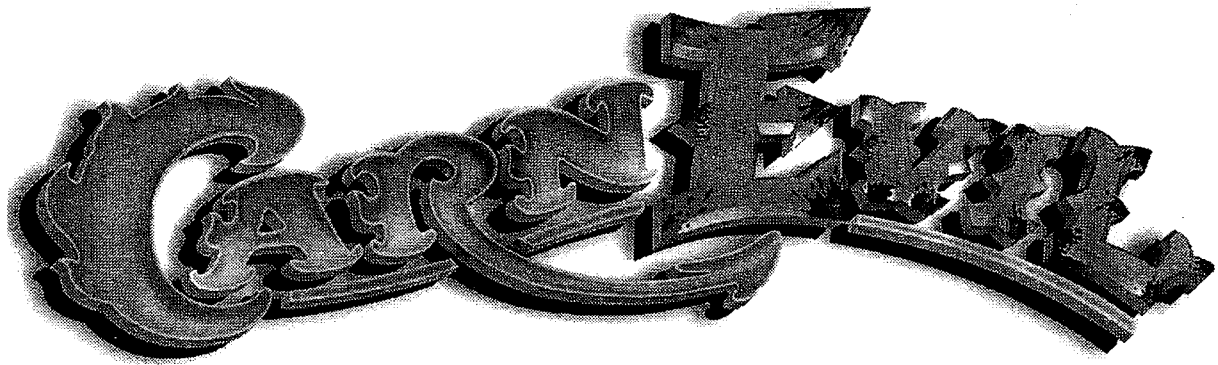

2-PLAYER
DEDICATED
25" VIDEO
GAME

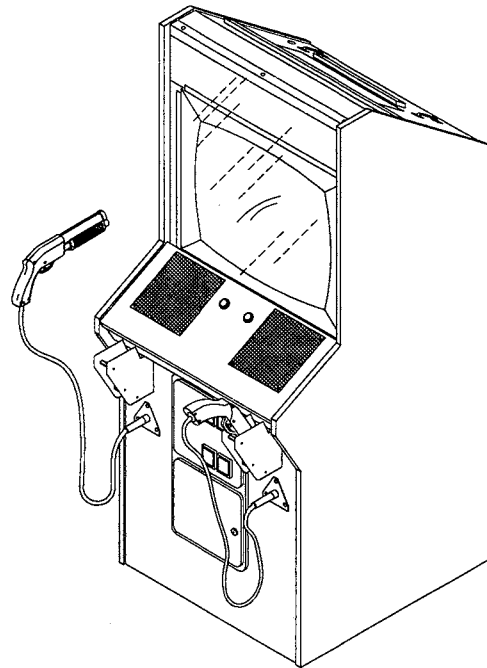

Operation Manual, Including...

- Installation & Operation
- Testing & Problem Diagnosis
- Parts Information
- Wiring Diagrams

Midway Games Inc.
3401 North California Avenue
Chicago, Illinois 60618-5899
USA



DECLARATION OF CONFORMITY

MIDWAY GAMES INC

3401 N. CALIFORNIA AVE.
CHICAGO, IL 60618
U.S.A.

WE, HEREBY DECLARE UNDER SOLE RESPONSIBILITY THAT

THE MODEL: "CARNEVIL" 25" 40269,40369,40469,40769,40969,41069,41169,41269,
41469,41869,41969,42069,42169,42269,47269

TO WHICH THIS DECLARATION RELATES IS IN CONFORMITY
WITH THE FOLLOWING EUROPEAN PRODUCT SAFETY

ELECTROMAGNETIC COMPATIBILITY DIRECTIVE

(89/336/EEC AND AMENDMENTS 91/C162/08, 92/31/EEC,93/68/EEC

**ELECTRICAL EQUIPMENT DESIGNED FOR USE WITHIN
CERTAIN VOLTAGE LIMITS DIRECTIVE**

(73/336/EEC AND AMENDMENTS 88/C168/02, 92/C210/01,
93/68/EEC,94/C199/03, 95/C214/02)

AS IS VERIFIED BY COMPLIANCE WITH THE FOLLOWING

EN55014: 1993	EN61000-4-2: 1995
IEC 801-3: 1984 (EN61000-4-3)	EN61000-4-4: 1995
EN61000-4-5: 1995	EN335-1: 1995
IEC 335-2-82 (DRAFT)	

Date issued:

OCTOBER 21,1998

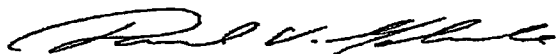

DAN GALARDE

CORPORATE V.P. OF QUALITY



CARNEVIL™

SECTION ONE

INSTALLATION, OPERATION & SERVICING



NOTICE: Information in this manual is subject to change without notice. MIDWAY reserves the right to make improvements in equipment function, design, or components as progress in engineering or manufacturing methods may warrant.

Fill out and mail in the Game Information Card. Be sure to include the game serial number from the label on the rear of the cabinet. For your records, write the game serial number in the manual. **SERIAL NUMBER**

SAFETY INSTRUCTIONS

The following safety instructions apply to operators and service personnel. Read these instructions before preparing your game for play. Other safety instructions appear throughout this manual.

DEFINITIONS OF SAFETY TERMS

DANGER indicates an imminent hazard. If you fail to avoid this hazard, it **WILL** cause death or serious injury.

WARNING indicates a potential hazard. If you fail to avoid this hazard, it **COULD** cause death or serious injury.

CAUTION indicates a potential hazard. If you fail to avoid this hazard, it **MAY** cause minor or moderate injury. **CAUTION** also alerts you about unsafe practices.

NOTICE indicates information of special importance.



WARNING: TRANSPORTING GAMES. This game contains glass and fragile electronic devices. Use appropriate care when transporting this game. Avoid rough handling when moving the cabinet. Do not move this game with the power on.



WARNING: DISCONNECT POWER. Always turn the power OFF and unplug the game before attempting service or adjustments. Installing or repairing PC boards with power ON can damage components and void the warranty. Be sure that you securely install ground wires.



WARNING: GROUND GAMES. Avoid electrical shocks! Do not plug in a game until you have inspected and properly grounded it. Only plug this game into a grounded, three-wire outlet. Do not use a "cheater" plug, or cut off the ground pin on the line cord.



WARNING: AVOID ELECTRICAL SHOCKS. This video game system does not utilize an isolation transformer. Internal, cabinet A.C. isn't isolated from the external, A.C. line.



WARNING: HANDLE FLUORESCENT TUBE AND CRT WITH CARE. If you drop a fluorescent tube or CRT and it breaks, it will implode! Shattered glass can fly eight feet or more from the implosion.



CAUTION: CHECK POWER SUPPLY LINE VOLTAGE SELECTOR SWITCH. Set the 110/220 VAC selector on the power supply for the correct local line voltage. Check the selector setting before switching on the game.



CAUTION: USE PROPER FUSE. Avoid electrical shock! Replacement fuses must be of the same type as those they replace. Fuse voltage and current ratings must match ratings on the original fuse.



CAUTION: ATTACH CONNECTORS PROPERLY. Be sure that printed circuit board (PCB) connectors mate properly. If connectors do not slip on easily, do not force them. A reversed connector may damage your game and void the warranty. Connector keys allow a connector to fit only one set of pins on a board.



CAUTION: TAKE CARE WHEN SHIPPING HARD DISKS. The hard disk drive must be packed in an anti-static bag. When shipping the drive for repair or replacement, pack it in an approved container (P/N 08-8068). Never stack or drop hard disk drives.



EPILEPSY WARNING

A very small portion of the population has a condition which may cause them to experience epileptic seizures or have momentary loss of consciousness when viewing certain kinds of flashing lights or patterns that are present in our daily environment. These persons may experience seizures while watching some kinds of television pictures or playing certain video games. People who have not had any previous seizures may nonetheless have an undetected epileptic condition.

If you or anyone in your family has experienced symptoms linked to an epileptic condition (e.g., seizures or loss of awareness), immediately consult your physician before using any video games.

We recommend that parents observe their children while they play video games. If you or your child experience the following symptoms: dizziness, altered vision, eye or muscle twitching, involuntary movements, loss of awareness, disorientation, or convulsions, **DISCONTINUE USE IMMEDIATELY** and consult your physician.

PRODUCT SPECIFICATIONS

Operating Requirements

<u>Location</u>	<u>Electrical Power</u>	<u>Temperature</u>	<u>Humidity</u>
Domestic	120VAC @ 60Hz 3.0 Amps	32°F to 100°F	Not to exceed 95% relative
Foreign	230VAC @ 50Hz 2.0 Amps	(0°C to 38°C)	
Japan	100VAC @ 50Hz 3.0 Amps		

Cabinet Statistics

<u>Shipping Dimensions</u>	<u>Shipping Weight</u>	<u>Design Type</u>
Width 29.5" (75 cm)	340 Lbs. (154.5 kg.)	Dedicated Video Game with Optical Shotguns
Depth 38.0" (96.5 cm)		
Height 72.5" (184.2 cm)		

Equipment Characteristics

<u>Video Display Monitor</u>	<u>Audio System</u>	<u>Currency Acceptors</u>
Standard Resolution RGB 25" (63.5 cm) CRT	Digital Stereo Sound with 6x9" (15x23 cm) Full Range Speakers	2 Coin Mechanism, Coin Counter Dollar Bill Validator Ready Electronic Coin Acceptor Ready

Game Characteristics

<u>Player Variables</u>	<u>Operator Variables</u>	<u>Diagnostics</u>
1 or 2 players per game High Score Recognition	Coinage, Game Options Difficulty, Volume, Audits, Statistics	Automatic Power-Up Self-Test Manual Multi-Level Menu System

INSTALLATION & INSPECTION



WARNING: The cabinet is top heavy. Use the two handles when moving the cabinet.

1. Remove all items from the shipping containers and set them aside. Inspect the exterior of the cabinet, control panel, and guns for any damage. Pay special attention to cabinet edges, seams, and corners.
2. Remove and save the screws at the top and sides of the rear door. Unlock the rear door, then lift it off of the cabinet and set it aside. Inspect the cabinet interior for any signs of damage. Check all major assemblies to assure that they are mounted securely. Check the shotguns for signs of damage.
3. The coin door keys are attached to a trigger on one of the guns. Unlock and open the coin door. The cash box door and rear door keys are located on a key hook attached to the rear of the coin door. Unlock and open the cash box door. Remove the spare parts stored in the cash box.
4. Leg levelers and nuts are located in the spare parts. Install one nut onto each leg leveler and hand turn it up against the base of the leg leveler. Install one leveler with its nut into the threaded hole in each corner of the cabinet. Turn them all the way into the holes, but do not tighten at this time.
5. Refer to the Cabinet Wiring Diagram (Section 4), and check to see that all cable connectors are correctly secured. *Do not force connectors; they are keyed to fit in only one location.* Bent pins and reversed connections may damage your game and void the warranty.
6. Locate the gun holster assemblies. There are three mounting holes in a triangular pattern on either side of the coin door. Orient the holsters over the holes and install with tamper resistant screws.

7. An extra padlock may be installed to secure the rear door. A hasp is located in the spare parts bag. Remove the two lock bracket nuts from inside the cabinet, above the rear door opening. Slide the hasp onto the bolts so that it protrudes from the hole in back of the cabinet. Reinstall nuts and tighten.
8. Modify the lock plate at the top of the rear door. Remove the bolts and nuts from the lock plate, then rotate the plate so that the slot will be above the door. Reinstall the bolts and nuts and tighten firmly.

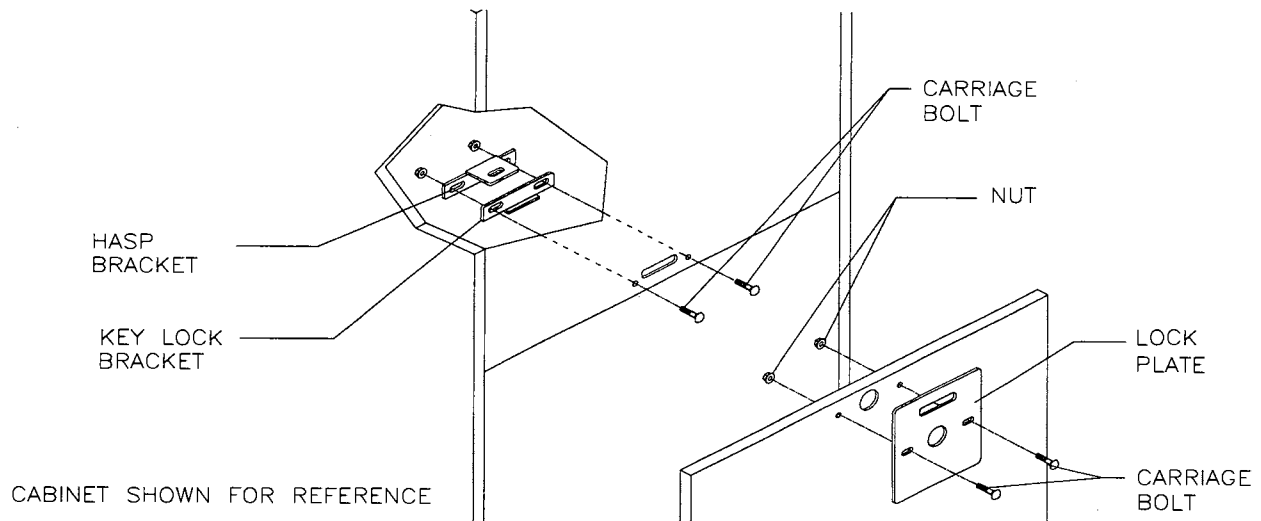

9. The power cord is with the spare parts. Remove and save four screws from the line cord cover plate at the rear of the cabinet. Match the holes on the IEC plug with the prongs in the receptacle and push firmly to seat the line cord. Route the cord away from cabinet wheels and foot traffic areas. Hang excess cord on the plastic clip near the vent.

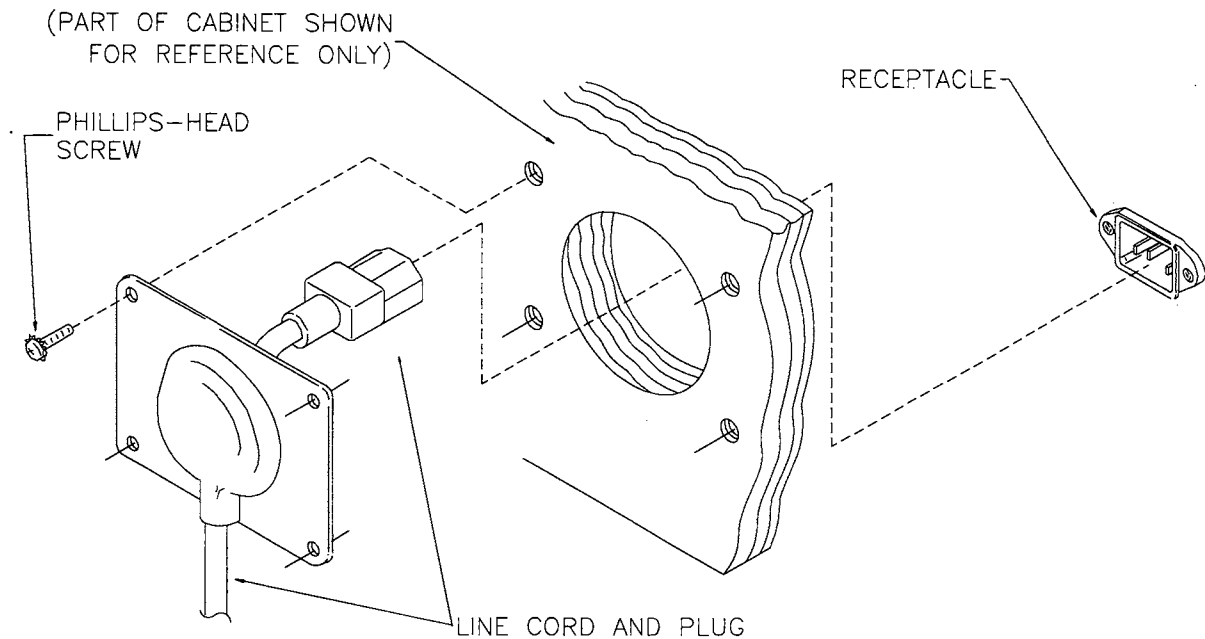

LINE CORD INSTALLATION



CAUTION: CHECK POWER SUPPLY LINE VOLTAGE SELECTOR SWITCH. Set the 110/220 VAC selector on the power supply for the correct local line voltage. Check the selector setting before switching on the game.

10. Reinstall the rear door onto the cabinet and close it. Lock the rear door and remove the key. If required, install the extra padlock through the hasp at this time. Install the screws at the top and sides of the rear door and tighten snugly. Close and lock the cash box and coin doors.



NOTICE: Tamper resistant screws and matching wrench are provided with this game for additional security. Four tamper resistant screws and one wrench are located in the spare parts bag. If desired, replace the original screws with the tamper resistant screws. Tighten the screws firmly with the wrench.

11. Move the game to its intended location. Lower each leg leveler until the cabinet is stable and level. Adjust as required to raise wheels and distribute weight equally on each corner. Tighten the nuts.
12. Plug the game into a grounded (3-terminal) AC wall outlet. Switch ON the game, using the ON/OFF switch at the top left rear of the cabinet. The game will power up and begin self-diagnostics. If no errors are found, the game will automatically enter its "attract" mode of operation. Unlock and open the coin door. Locate the control switches. Press TEST MODE to enter the Menu System.
13. Perform a gun test on each shotgun. Access to this test is from the Diagnostic screen of game's Menu System. See Section Three for a detailed description of the Menu System. The gun test verifies that the shotguns function properly to allow normal game play.
14. If necessary, calibrate the shotguns. Access to the calibration feature is from the Utilities screen of game's Menu System. See Section Three. Calibration restores shotgun accuracy to original factory level of performance. Since player satisfaction depends on gun performance, you should recalibrate and test shotguns periodically.

CABINET ASSEMBLY

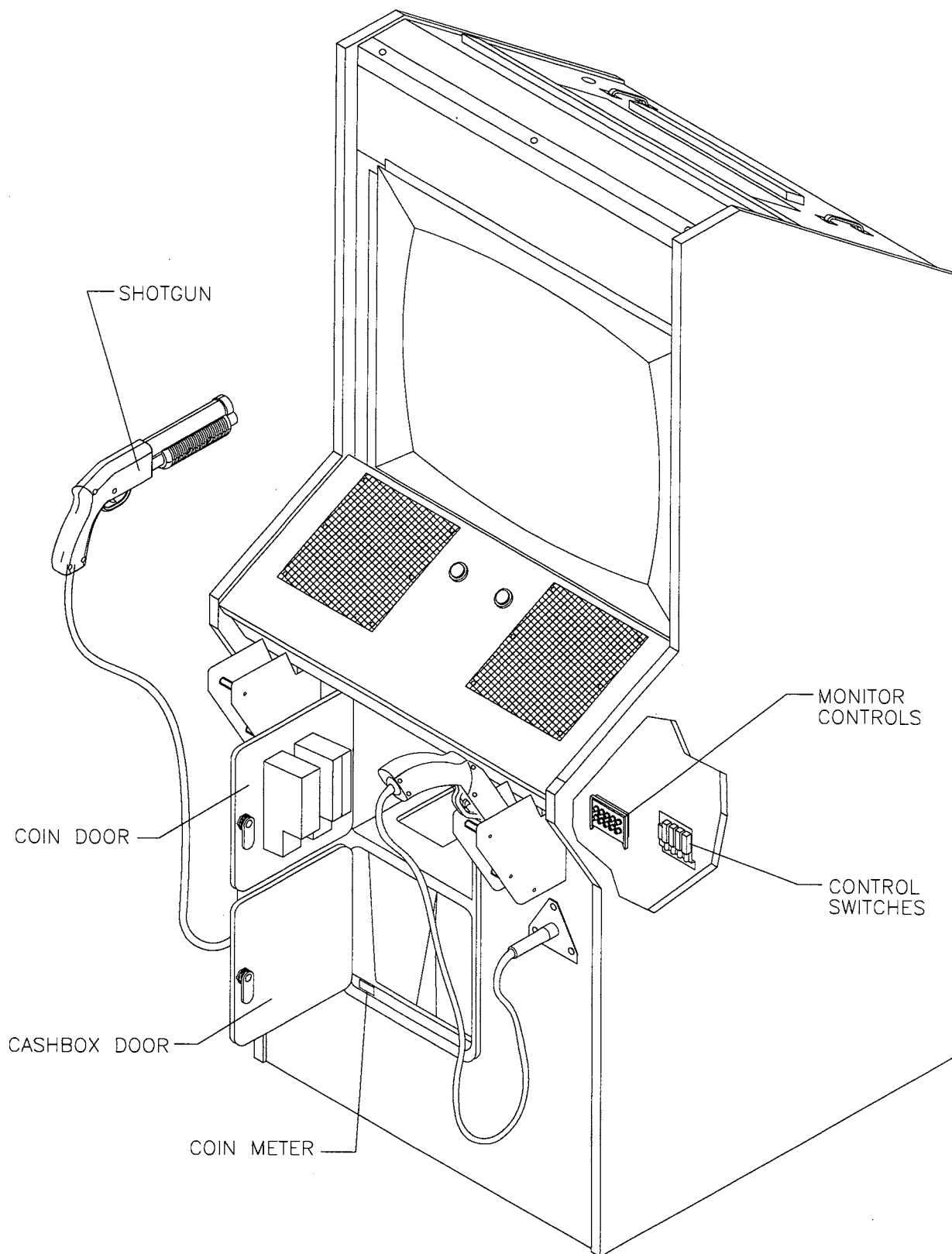

FRONT VIEW OF CABINET

MAINTENANCE

◆ Viewing Glass

It is not necessary to switch off power to the game to clean the glass. Apply a mild glass cleaner to a clean cloth or sponge. Use this to wipe the viewing glass. ***Do not apply the cleaner directly on the glass!*** Liquid could drip down into switch or motor circuits and cause erratic game operation.

◆ Cabinet

Use only non-abrasive cleaners to avoid damaging game graphics. Apply cleaner to a clean cloth or sponge. Use this to wipe the screen clean. ***Do not apply the cleaner directly on the cabinet!***

◆ Shotguns

Dirt or debris on a shotgun lens can affect accuracy. Apply the cleaner to a clean cloth or cotton swab, and then use this to wipe the lens clean. ***Do not apply cleaner directly into the gun barrel!***

SERVICING

Only qualified service personnel should perform maintenance and repairs. The following product guidelines apply to all game operators and service personnel. Notes, cautions and warnings appear throughout this manual where they apply. Read the SAFETY pages thoroughly before beginning service.

◆ Shotguns

Switch off power to the game. Unlock and open the coin door. Disconnect the shotgun cable from the wiring harness. Remove the locking nuts. Lift the gun cable mount off the front of the cabinet. Retain carriage bolts and nuts from the mount for reinstallation. Reattach the ground connection. Check that the gun cable rotates freely in its mount. Reinstall the carriage bolts. Tighten the locking nuts.

To disassemble a shotgun, lay the gun on a work surface and remove the screws. Separate the gun halves, beginning at the handle. Take care not to dislodge parts (the trigger is spring loaded.) Clean the lens to remove fingerprints and dust. If you removed any shields from the gun, reinstall them. After re-installation, verify that a good electrical connection exists between the shield and cable ground. Test the pump action to insure it does not bind. Always recalibrate a shotgun after servicing.

◆ Coin Mechanism

Switch off power to the game. Unlock the coin door and swing it open. To clean a coin mechanism or replace it with a different type, unlatch and remove it. After reinstallation, ensure that the mechanism seats fully in the holder. Close and lock the release latch, and then close the door. Turn on the game and change the mechanism setup. Test known good and bad coins to verify operation.

◆ Dollar Bill Validator

(Use MARS AE2411-U5 U.L. Recognized currency changer)

Dollar bill validators or other currency acceptors may be installed in games that were manufactured with the additional wiring connector factory installed. Switch off power to the game and unplug the A.C. line cord. Unlock the coin door and swing it open. Read the door label for additional information. Remove nuts, spacers, and the cover plate from the door. Change switch settings and make other adjustments before mounting the unit. If the manufacturer has supplied an adapter plate, place it over the door cutout. Install spacers on threaded studs. Align validator mounting holes with the studs. Seat the unit in the door opening. Install the nuts and tighten them firmly. Attach the ground wire (green with a yellow stripe) lug to the door ground stud next to the hinge. Mate the wiring harnesses. Press down on connectors to fully seat them. Route wires away from the door edges and hinge. Check for proper bill chute alignment. Plug in the line cord and turn on the game. Change the mechanism setup and pricing as required. Test known good and bad bills to verify proper operation. After you are satisfied with validator operation, close and lock the coin door.

Bill Acceptor Specifications

Pulse Width	50 mS minimum on; 50 mS minimum off
Pulses	1 pulse per dollar
VOL	0.4V @ 5mA
VOH	3.5V @ -0.4mA

◆ Coin Meter

Switch off power to the game. Unlock the cash door and swing it open. The meter is at the lower left corner of the door opening. Record the meter count before testing or replacement.

Insert a finger through the access hole under the cash tub. Locate the meter wires. Disconnect the harness at the connectors. Remove front screws and slide the meter out. Ensure that the replacement unit has a protective diode connected across the terminals to prevent driver circuit damage.

CABINET FRONT VIEW

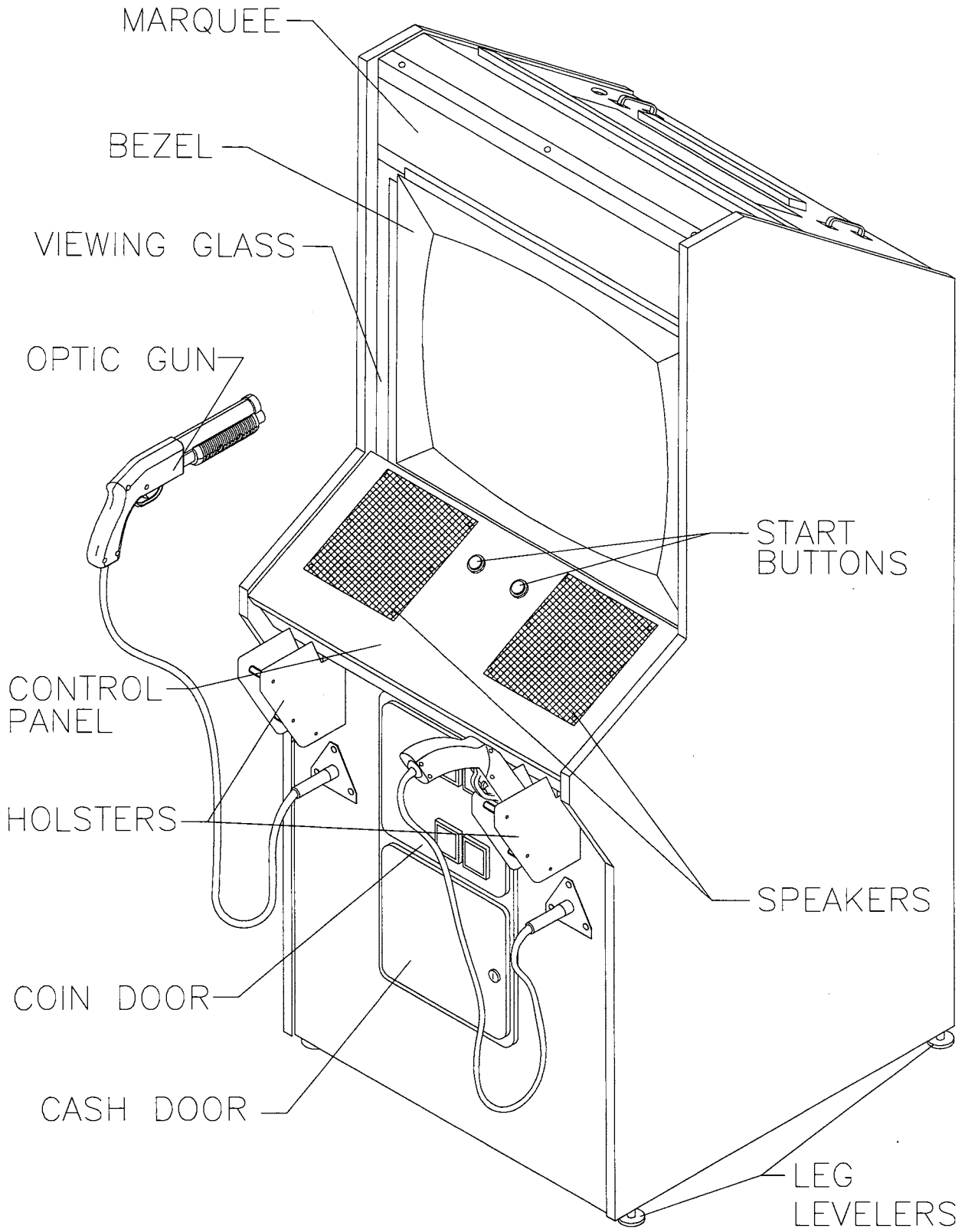

EXTERNAL COMPONENTS

◆ **Viewing Glass**

Remove the screws from the top of the cabinet directly over the marquee. Lift the retaining strip of the cabinet. Tilt the glass slightly forward, grasp it firmly by its edges, and lift it out of the cabinet. The marquee artwork may be removed if required. Clean and inspect the lamp before reassembling.

◆ **Fluorescent Lamp**

Remove the screws from the rear lamp access panel. Unlock it and lift from the cabinet. Reach over the top of the assembly and grasp the tube. Give it a quarter turn and pull it out from its sockets. The electronic ballast in this assembly does not require a separate starter. Carefully place a new tube into the socket and rotate it a quarter turn to reinstall. Clean the tube to remove fingerprints and dust.

◆ **Fluorescent Light Assembly**

Remove the screws from the rear lamp access panel. Unlock it and lift from the cabinet. Disconnect the power cable from the fluorescent light assembly. Loosen but do not remove the fasteners holding the assembly to the cabinet. If present, remove the ground wire. Slide the assembly slightly forward to disengage the screws from the keyholes. Lift the assembly and guide it out of the cabinet.



WARNING: If you drop a fluorescent tube or a CRT and it breaks, it will implode! Use care in handling. Keep the item in its protective packaging until it is installed.

◆ **Speakers**

The grilles and the speakers come out from the front. Remove the screws and set the grilles aside. To avoid damaging a speaker, remove upper mounting screws first, and replace them last. Remove the speakers from the enclosure just enough to expose the terminals. Label and disconnect the wires. Refer to the Wiring Diagram (Section Four) for speaker wiring information. *Tighten screws snugly. Do not use excess force when removing or tightening screws threaded into plastic or particle board.*

◆ **Control Panel Switches**

Remove grilles and speakers. Label and disconnect wires. Separate the switch from its button housing. Bend the large prong away from the switch just enough to slide the switch off the housing. Unscrew the switch mounting nut and pull the entire button assembly out the front of the control panel.

◆ **Power Supply**

Switch off power to the game. Unlock and remove the rear door. Unplug the IEC A.C. connector from the rear and the D.C. connector from the front of the assembly. Remove two top and two bottom screws holding the supply to the power chassis, then lift it off the power chassis. Note voltage setting.

To install a power supply, remove the voltage switch cover if necessary and set the voltage to the correct value. Set the supply on the power chassis and align the mounting holes. Install the four screws and the two power connectors.

CABINET REAR VIEW

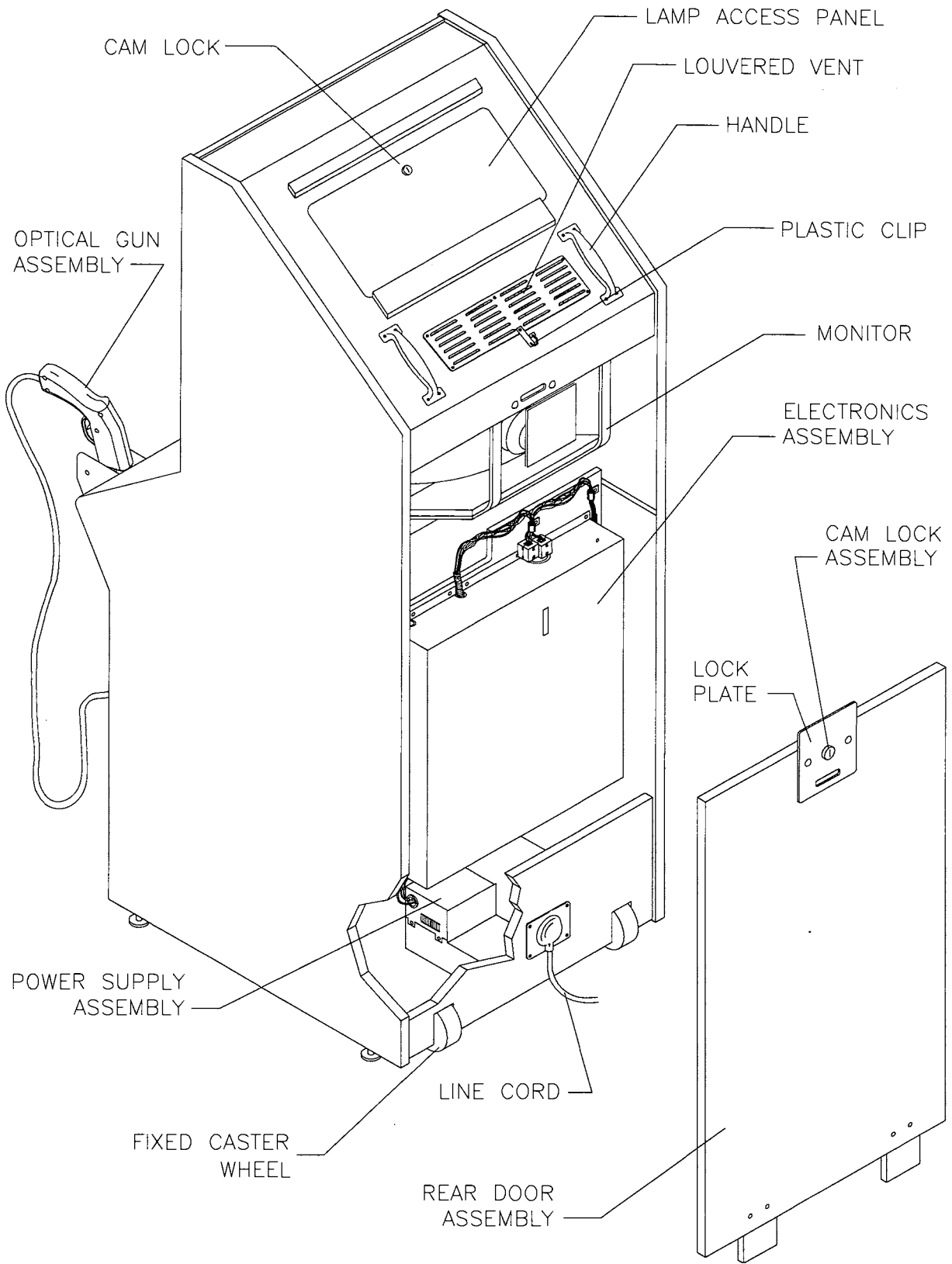



INTERNAL COMPONENTS

◆ **Monitor Bezel**

Remove the viewing glass. Grasp the monitor bezel at the bottom and lift it out of the groove.

◆ **Monitor**

Read these precautions thoroughly before beginning this procedure.

	WARNING: The video monitor is heavy, with most of the weight toward the front of the assembly. Be certain that it is firmly supported as it is removed from the cabinet.
	WARNING: The video monitor does not require isolation from the A. C. line voltage in normal game operation. However, when operating the monitor outside of the cabinet or servicing the monitor on a test bench, <i>you must isolate the monitor circuits from line voltage with an isolation transformer.</i>

Switch off power to the game. Unlock and remove the rear door. Disconnect the monitor from the wiring harness, remote adjustment board, and ground wires. Remove the retaining strip and the viewing glass. Remove the monitor bezel and both barrier panels. Remove the fasteners holding the monitor frame to the upper and lower mounting brackets. Pull the monitor carefully from the cabinet and set it in a safe place. Remove the remote adjustment board from the cabinet and reconnect it to the monitor before servicing or replacement. Clean the monitor face and the bezel before reinstalling.

◆ **CPU Fan Assembly**

Switch off power to the game. Unlock and open the rear door. To expose the CPU Board Assembly, remove the perforated metal cover from the game electronics. Disconnect the fan connector from the wiring harness. Remove fasteners and lift the fan assembly out of cabinet. Separate the mounting bracket from fan. Retain the bracket and the connector for reuse if a different fan must be installed.

◆ **CPU Board Assembly**

Switch off power to the game. Open the rear door. To expose the CPU Board Assembly, remove its perforated metal cover. Carefully note the orientation of the JAMMA connector and the other cables. Extract the harness and the hard disk drive ribbon cable from the board connectors. Remove CPU Board Assembly mounting screws. Lift the board out of the cabinet and set it in a safe place. Use anti-static bags or protective containers from new parts to store boards that you don't plan to reinstall.

◆ **Gun Interface Board Assembly**

Switch off power to the game. Unlock and remove the rear cabinet door. To expose the Gun Interface Board Assembly, remove the perforated metal cover. Disconnect the wiring harness and the fuses from the interface board assembly. Remove two large and two small screws holding the board assembly in place and retain them along with their washers. Lift the board out of the cabinet and set it in a safe place. Set the replacement board assembly over the CPU board, align the holes and install the screws, small ones first. Reinstall the fuses and reconnect the wiring harness to this board.

GAME ELECTRONICS

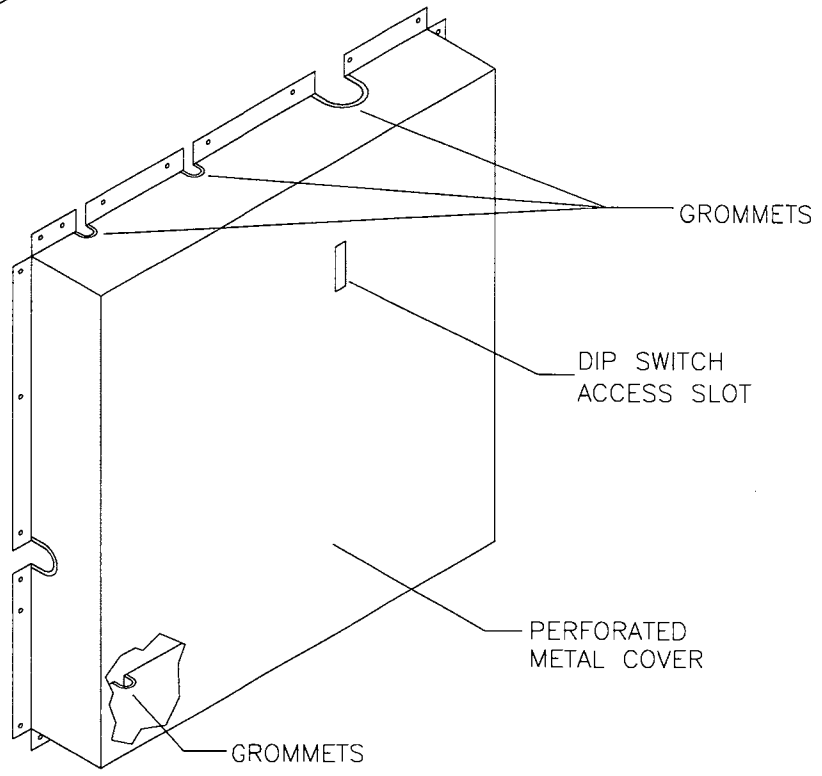
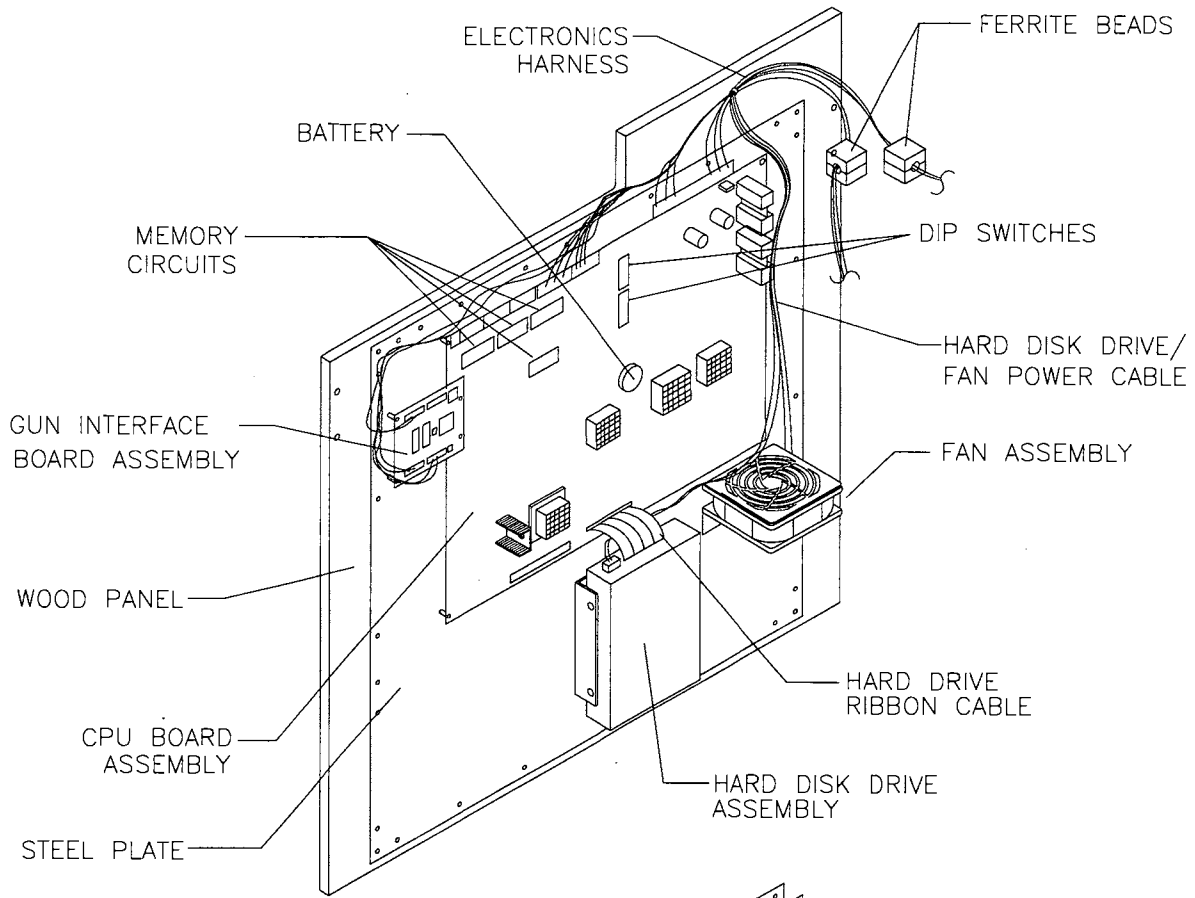

INTERNAL COMPONENTS

◆ **Hard Disk Drive**

Use an anti-static bag and approved shipping container (P/N 08-8068) to return the hard disk drive assembly to your distributor. Switch off power to the game. Unlock and remove the rear cabinet door. Remove the perforated metal cover over the game electronics. Disconnect the D.C. power cable from the hard disk drive. Unplug the ribbon cable from the hard drive and leave it attached to the CPU Board. Carefully loosen the screws and lift the drive assembly out of its mounting bracket. Remove the screws and reuse them if a different hard disk drive assembly is to be installed.



NOTICE: Hard disk drives are very fragile! Handle them with care. Do not stack or drop hard disk drives. Keep the disk drives away from magnets, heat and vibration.

◆ **Memory**

The ROM (Read Only Memory) circuits contain the computer operating instructions for this game. Switch off power to the game. Unlock and remove the rear door. Remove the perforated metal cover. Carefully note the Integrated Circuit position, then remove the device with a chip extraction tool. To reinstall memory circuits, orient the device over its socket and press firmly to seat pins. *Do not force.*



CAUTION: Static electricity builds up on your body. This static can damage or destroy sensitive the game circuits. **BEFORE** touching or handling electronic assemblies, discharge static electricity by touching the power supply chassis.

◆ **Battery**

Switch off power to the game. Unlock and remove the rear door. Remove the perforated metal cover. Carefully note the battery position, then gently lift the contact arm to release tension. *Do not bend the arm with excess force.* Slight finger pressure may be needed to pry the cell from its holder. Slide the battery out and remove from the cabinet. *Avoid direct shorts across terminals or terminals to ground.*



CAUTION: Danger of explosion if battery is incorrectly installed. Replace only with the same or equivalent type as recommended by the manufacturer. Dispose of used batteries according to instructions printed on the battery or the manufacturers packaging.

GAME OPERATION

STARTING UP

Whenever you turn on the machine or restore power, the system executes boot ROM code. The boot ROM contains self-diagnostic tests. These tests automatically verify and report the condition of the disk drive and other hardware. The screen is blank during these tests. If the hardware fails a test, the system displays an error message. The message appears for 30 seconds or until someone presses a button.

- If nobody presses a button, the system quickly completes tests, and then loads game software.
- To skip boot ROM tests and activate the Menu System, press and hold the TEST MODE button.

Having passed power-up tests, the system enters Attract Mode. Attract Mode consists of typical game scenes and sounds, alternating with high scores. Attract Mode continues until game play commences.

Players insert currency to start the game. Then they select a CarnEvil territory. As a player chooses a shotgun, the player also selects a character. The game identifies one character with green shotgun blasts. The game associates the second character with purple shotgun blasts. Each character receives a starting health level. Play begins after a countdown period. The game progresses until players exhaust their characters' health. If players choose not to continue, then the system returns to Attract Mode.

GAME RULES

ONE OR TWO PLAYERS

The player or players insert currency to start the game. Each player chooses a gun and presses the nearest START button. At the CarnEvil ticket booth, either player selects a territory to begin an adventure. Indicator bars at the sides of the screen track remaining ammunition for each player.

PLAYER CONTROLS

◆ START Buttons

These buttons allow players to begin or continue play.

◆ SHOTGUNS

Use a shotgun to shoot killer clowns and other enemies. Also use a shotgun to shoot player health and gun-upgrade symbols. To reload the gun, pump it or shoot off-screen.

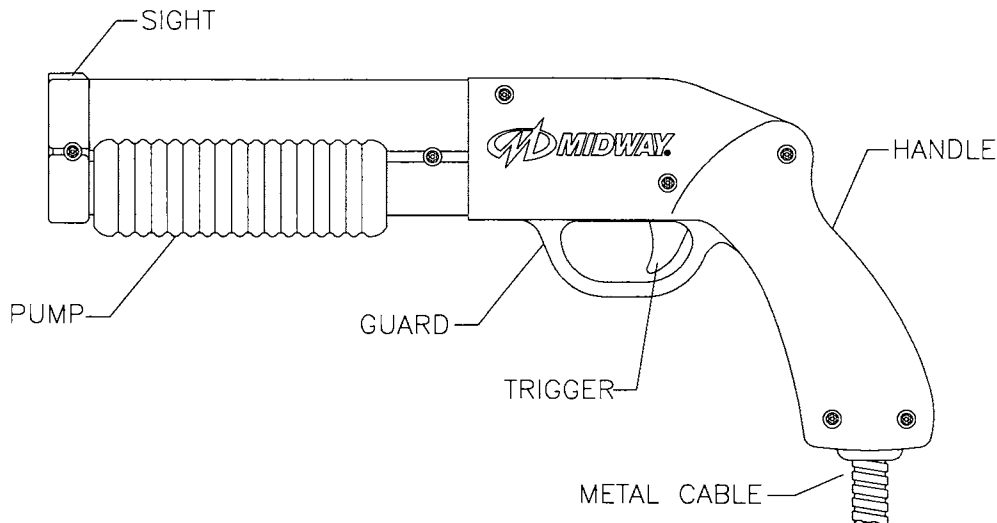

SHOTGUN PARTS



OPERATOR CONTROLS

CABINET CONTROLS

- ◆ **The DIP Switches** are beneath the monitor, on the main PC board. Access these switches by opening the rear door. DIP switches set some system variables. You can set other variables with control switches.
- ◆ **The Monitor Remote Control Board** is beneath the monitor, on the rear cabinet wall. Open the coin door to access controls. Use monitor controls to adjust the video display for optimum viewing.
- ◆ **The POWER Switch** is at the rear of the cabinet. If you stand behind the cabinet, you'll find the switch on the top-right side. This switch turns off the game, but does not reset game variables.

CONTROL SWITCHES

- ◆ **The SERVICE CREDITS Button** is behind the coin door, on a rear wall bracket. This button allots credits without changing the game's bookkeeping total.
- ◆ **The TEST MODE Button** is behind the coin door, on a rear wall bracket. Actuating TEST MODE causes the game to enter the menu system. Press the TEST MODE button briefly to run automatic tests. To make changes, press and hold TEST MODE until the system menu appears.
- ◆ **VOLUME DOWN and VOLUME UP Buttons** are behind the coin door. You'll find them on a rear wall bracket. These buttons set game sound levels. To make minor changes, press either button briefly. To make major changes, press and hold a button.

	NOTICE: You must adjust Attract Mode volume independently of Game Mode volume. For greater profits, increase volume levels to draw attention to this game.
	NOTICE: To reach control switches, unlock and open the coin door.
	NOTICE: The 25-inch CarnEvil machine has no factory-installed tilt switch.

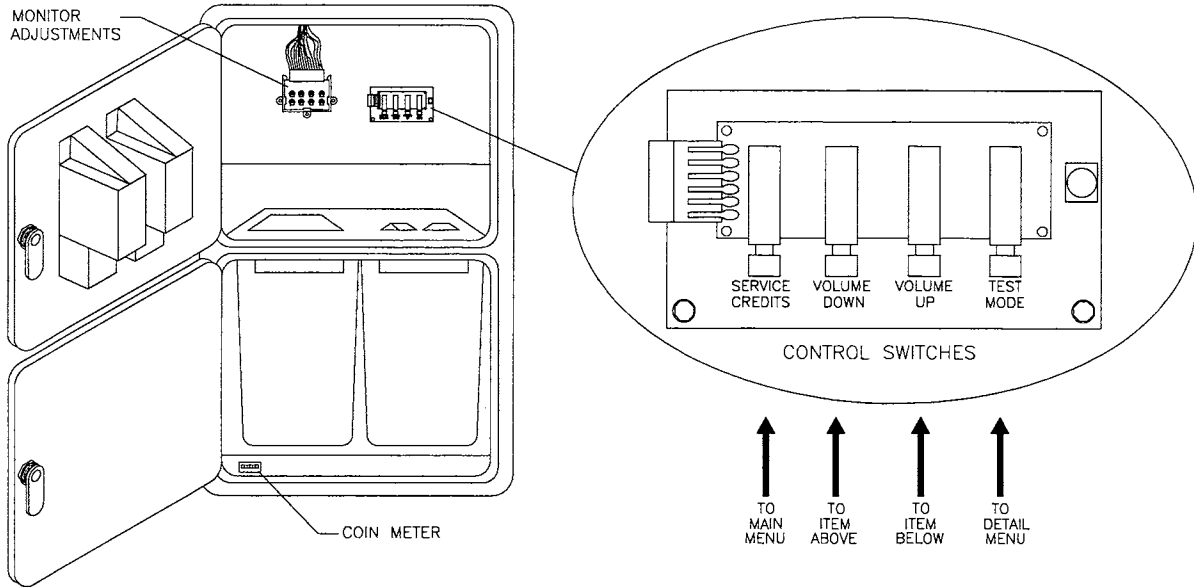

CONTROL SWITCH LOCATIONS

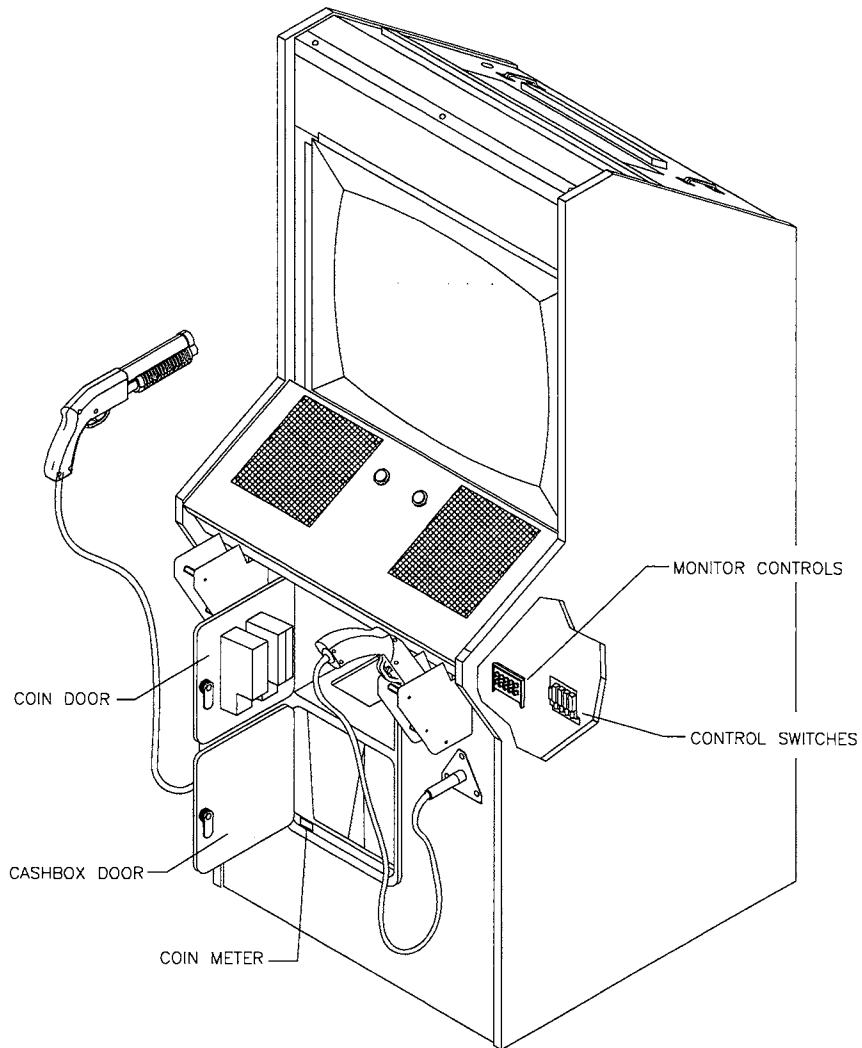

PLAYER CONTROL LOCATIONS

GAME FEATURES

CarnEvil is a dark, gloomy, 3-D horror movie, and the player is the ultimate hero. The player must battle up to 40 terrifying villains, each with its own threatening capabilities. Among these are killer clowns, murderous mimes, a savage Santa, marauding maggots and jugular Junior.

Deep within CarnEvil lurk many territories, each with unique, blood-curdling perils and sinister secrets. CarnEvil proclaims a sardonic welcome to its every dank domain. Players dare to enter the Haunted House, Rickety Town or the Freak Show. Skill, craft and discipline earn entry into elite domains, such as the bestial Big Top. Here CarnEvil challenges the superior player to a heightened play level.

For the intrepid player, a blazing shotgun is the only way out. The player must remember this essential rhythm: Pump and fire, pump and fire! Then the player moves cautiously forward, flushing out gruesome enemies that never see the daylight.

Threatened by killer clowns, bats, spiders, freaks and others, the player must exterminate them all. If an enemy draws blood, then the player's health declines. The player achieves extra points by eliminating ravenous villains before they devour the heroine. Yet should a misplaced shot dispatch the lovely heroine, the player pays a penalty.

As play commences, the gun fires single shots, like a pistol. Shooting bullet-shaped symbols upgrades the player's weapon. Upgrades allow the gun to temporarily become a full-fledged shotgun or a machine gun. In all gun modes, the player must periodically pump the gun to reload it. Another way to reload the gun is to aim off screen and press the trigger. The player improves his health by shooting heart-shaped symbols. Then, restored and fortified, the player dares to plunge forth into the next, nightmarish territory.

The screen displays and constantly updates player scores. As players exit a territory, the screen indicates shooting accuracy percentages for each player. As each play level concludes, top scorers may enter initials or names with a shotgun. CarnEvil displays these initials in a high score table.

CARNEVIL™

SECTION TWO

DIAGNOSTIC, AUDIT & ADJUSTMENT MENU SYSTEM



NOTICE: Information in this manual is subject to change without notice. MIDWAY reserves the right to make improvements in equipment function, design, or components as progress in engineering or manufacturing methods may warrant.

MENU SYSTEM

AUTOMATIC TESTS

Whenever you switch the game between Play Mode and the menu system, the self-test routine activates. This routine, which isn't part of the menu system, runs automatically. Its purpose is to detect faults that prevent the game or menu system from operating properly. Messages appear on the screen as each item runs. These messages may describe detected errors. A self-test usually takes less than one minute to complete. Write down messages before proceeding to the menus or game play.

OPERATOR-SELECTED TESTS

The game's menu system includes a number of operator-selected, manual tests. In this system, a series of on-screen menus presents game variables and diagnostics. The Main Menu screen allows you to view information, make changes, or verify equipment operation. Each submenu screen displays one group of choices. A Detail Menu presents data or runs the required test. You must be at the Detail Menu level to detect errors, make changes, or activate tests.

SCREEN LAYOUT

Menu screens differ, but presented material remains in the same location each time.

- ◆ The color bar at the top center of each screen displays the current menu title.
- ◆ Data (menu items, video signals, statistics, reports, etc.) appears in the center of the screen.
- ◆ Messages (explanations, control functions, revision levels) display at the bottom of the screen.

MENU SYSTEM ORGANIZATION

You must activate the menu system manually. To play the game, you must also manually exit from the menu. Main Menu items appear in categories: Tests, statistics, audits, adjustments, etc.

- ◆ Tests verify proper equipment operation.
- ◆ Statistics and audits allow you to assess and customize game performance.
- ◆ Adjustments help you to customize game performance. For instance, you can restore factory default game settings. You can also calibrate player controls for accuracy.

Submenu screen items offer you choices within a category. Some items have no submenu, while others may have more than one. You can return to the previous menu or go on to the next menu.

Detail Menu screen items contain specific information. You must interact with the system to achieve results or make changes. You can always return to previous menus from Detail Menu screen items.

Control functions appear on a menu screen. Use VOLUME UP and VOLUME DOWN buttons to highlight an item on any menu. (These buttons are inside the coin door.) *You can only select one highlighted item at a time.* To select a highlighted item, press the TEST MODE (rightmost) pushbutton inside the coin door. To return the game to play, highlight "EXIT," then press TEST MODE.

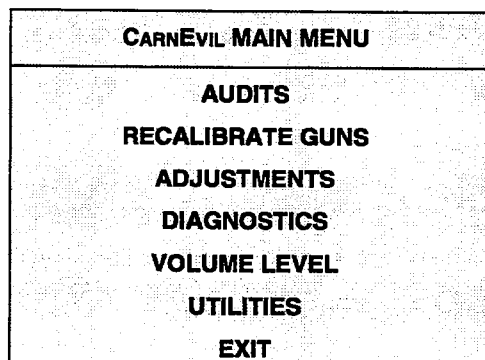

MAIN TEST MENU

AUDITS

Select "AUDITS" at the CarnEvil Main Menu. The Audits menus permit you to review game play statistics. Additional menus give detailed reports for each player position on game starts, ends, cabinet abuse, fault conditions, etc.

Highlight a line item with the middle two control buttons inside the coin door. Select the option with the right control button. The screen displays a list of the statistics available to you. Select an item to view the detailed report.

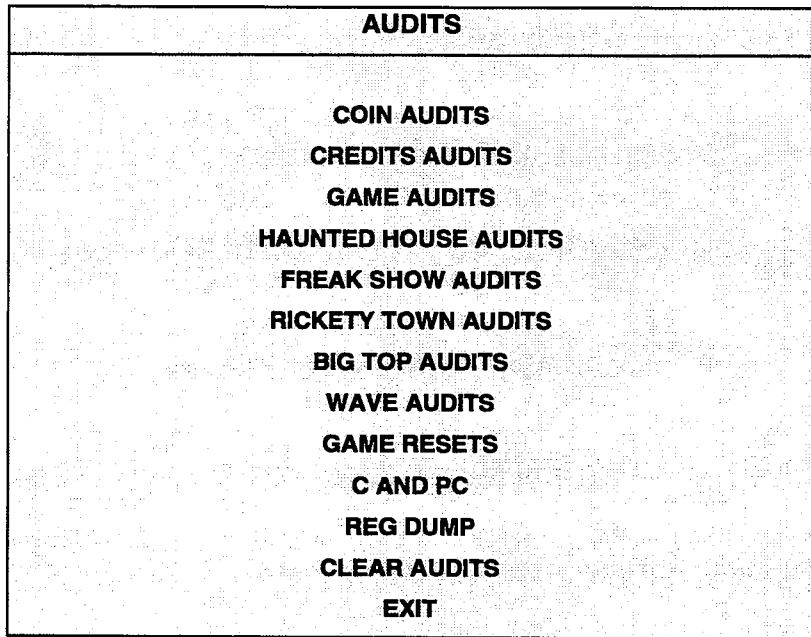

AUDITS SUBMENU

Data in the Audits menus helps you to keep records of the game's popularity and earning potential. Each entry on the Audits Submenu is the subject for an entire screen of bookkeeping information. Use the highlight bar to select the desired subject.

Examine and record all game audit values before performing game service or repairs.



NOTICE: Be careful when clearing audit information. Once you clear data, you cannot restore it.

COIN AUDITS

Select "COIN AUDITS" at the Audits Menu. The Coin Audits menu permits you to assess the currency collection. This report screen presents revenue quantities and other important game statistics.

Highlight a line item with the middle two control buttons inside the coin door. Select the option with the right control button. A menu screen appears as below.

COIN AUDITS - PAGE: 1	
LEFT SLOT COINS	XXXXXXXX
RIGHT SLOT COINS	XXXXXXXX
BILLS	XXXXXXXX
CENTER SLOT COINS	XXXXXXXX
EXTRA SLOT COINS	XXXXXXXX
GAME STARTS	XXXXXXXX
SERVICE CREDITS	XXXXXXXX
TOTAL PLAYS	XXXXXXXX
TOTAL COINS	XXXXXXXX

COIN AUDITS SUBMENU

The Coin Audits submenu reports total quantities of coins, bills or credits collected by each active device. The submenu does not calculate the value of the collected currency.

This screen reports information, but does not permit you to make changes. To reset the coin, bill, and credit counters to zero, use the Clear Audits menu.

We recommend that you examine and record audit information before you make changes. Once you've cleared the counters, you can't retrieve the previous data from the system.

CREDITS AUDITS

Select "CREDITS AUDITS" at the Audits Menu. The Credits Audits menu permits you to assess the currency collection. This report screen presents revenue quantities and other important game statistics.

Highlight a line item with the middle two control buttons inside the coin door. Select the option with the right control button. A menu screen appears as below.

CREDITS AUDITS - PAGE: 1	
CREDITS AVAILABLE	XXXXXXXX

CREDITS AUDITS SUBMENU

GAME AUDITS

Select "GAME AUDITS" at the Audits Menu. The Game Audits menus permit you to review the game play statistics.

Highlight a line item with the middle two control buttons inside the coin door. Select the option with the right control button.

GAME AUDITS - PAGE: 1	
TOTAL UPTIME	DBE
TOTAL PLAY TIME	1 ST CONTINUE
GAME STARTS	2 ND CONTINUE
GAME CONTINUES	3 RD CONTINUE
LEFT PLAYER	4 TH CONTINUE
RIGHT PLAYER	5 TH CONTINUE
1 PLAYER	6 TH CONTINUE
2 PLAYER	7 TH CONTINUE
SBLF'S	8 TH CONTINUE
TLF'S	9 TH CONTINUE
INITIALS ENTERED	10 TH CONTINUE
ZA CRC	11 TH CONTINUE
ZM CRC	12 TH CONTINUE
PATH CRC	13 TH CONTINUE
CAM CRC	14 TH CONTINUE
DBS	MORE CONTINUE

GAME AUDIT SUBMENU

The Game Audits menus report information but don't permit you to make changes. Examine and record information at GAME AUDITS before deleting data at CLEAR AUDITS.

LSW, TLF, SBLF, etc. are terms for internal record keeping counters used in this game.

CLEAR AUDITS

Select "CLEAR AUDITS" at the Audits Menu. The Clear Audits menu allows you to clear individual memory counters or to reset them all at one time.

Highlight a line item with the middle two control buttons inside the coin door. Select the option with the right control button. Options may be reset to factory defaults or changed after each viewing.

CLEAR AUDITS
CLEAR COIN AUDITS
CLEAR CREDITS AUDITS
CLEAR HAUNTED HOUSE AUDITS
CLEAR FREAKSHOW AUDITS
CLEAR RICKETY TOWN AUDITS
CLEAR BIG TOP AUDITS
CLEAR WAVE AUDITS
CLEAR GAME RESETS
CLEAR C AND PC
CLEAR REG DUMP
CLEAR ALL
EXIT

CLEAR AUDITS SUBMENU

You can reset any audit screen from the Clear Audits submenu. Choose any item to return the counters to zero.

- **Game Resets** keeps track of how the game responds to different player maneuvers.
- **C and PC** is an internal record-keeping list used to monitor game performance.
- **Clear All** simultaneously changes all audit categories to factory default values.

After you select an item, the game gives you the opportunity to escape from this change. For example:

ARE YOU SURE YOU WANT TO CLEAR COIN AUDITS?	
YES	NO

LAST CHANCE SUBMENU

Once you've selected and verified a clear function, the values reset and you can't restore them. We recommend examining and recording all utility values before making changes.

	NOTICE: Be careful when clearing audit information. Once you clear data, you can't restore it.
---	---

RECALIBRATE GUNS

Select "RECALIBRATE GUNS" at the CarnEvil Main Menu. Shotgun recalibration restores shotgun accuracy to original software performance. Of course, shotgun performance also depends on the condition of your game hardware. Since player satisfaction depends on gun performance, you should recalibrate and test shotguns periodically.

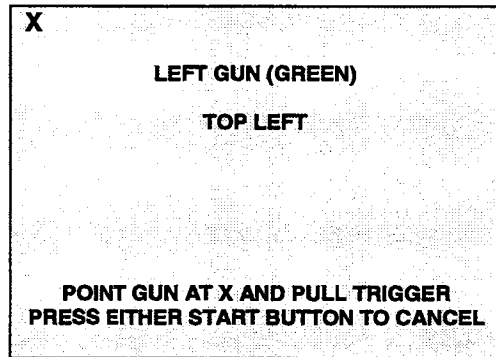

GUN CALIBRATION SCREEN 1

The Gun and Monitor Calibration screen opens. Now highlight "Gun Calibration." Again, select the option with the right control button. The Calibrate Guns screen opens. Turn room lights down to reduce glare that may interfere with gun operation. Before calibrating shotguns, examine shotgun barrels for dirt or debris. No amount of calibration and testing can fix a dirty optical system. The same rule applies to blown gun fuses, loose components, defective cables, etc.

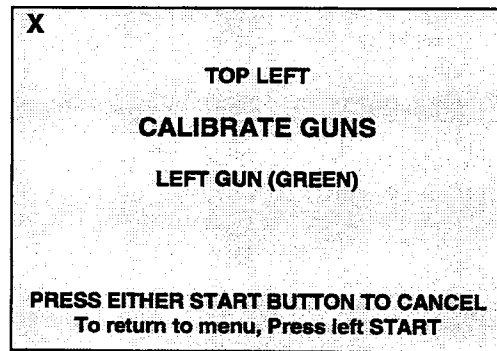

GUN CALIBRATION SCREEN 2

The screen specifies which gun to shoot. To avoid miscalibration, the other gun temporarily becomes inactive. Stand directly behind the shotgun holder and extend the cable to its full length. An "X" appears at the top-left corner of the screen. Aim precisely, so that the gun sight aligns with the "X." Fire the gun at the "X."

A second "X" appears at the bottom-right screen corner. Again, fire the gun at the "X." When you're done, return to the previous menu by pressing the left START button. Maintain maximum earnings by testing and recalibrating guns often.



NOTICE: Bright overhead lights occasionally interfere with optical gun operation. To eliminate this interference, reduce light levels and recalibrate the shotguns.

ADJUSTMENTS

Select "ADJUSTMENTS" at the CarnEvil Main Menu. The Adjustments menus permit you to change game characteristics. Use these screens to optimize game performance and earnings.

Highlight a line item with the middle two control buttons inside the coin door. Select the option with the right control button.

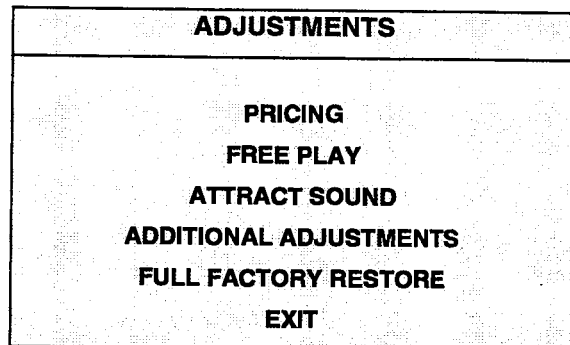

ADJUSTMENTS SUBMENU

PRICING

Select "PRICING" at the Adjustments Menu. The Pricing menus allow you to view current settings or change the cost of games. Custom pricing allows you to select the number of coins or credits required for each game. The game restores factory default values if you exchange the CPU Board or if the backup battery fails.

Highlight a line item with the middle two control buttons inside the coin door. Select the option with the right control button. You may reset options to factory defaults or change an options after viewing it.

We recommend examining and recording all pricing options before making changes.

You may save several custom prices and then choose between them as needed. Instructions for creating new price settings appear on the screen in sequence to guide you through the custom process.

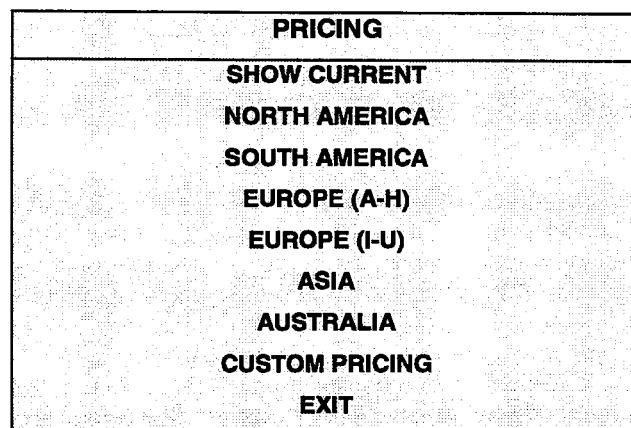

PRICING SUBMENU

An additional box appears on screen to explain the available functions as you select each item.

CURRENT PRICING

CURRENT PRICING USA 1	
LEFT SLOT UNITS	XX
RIGHT SLOT UNITS	XX
CENTER SLOT UNITS	XX
EXTRA SLOT UNITS	XX
BILL VALIDATOR UNITS	XX
UNITS PER CREDIT	XX
UNITS PER BONUS	XX
MINIMUM UNITS	XX
CREDITS TO START	XX
CREDITS TO CONTINUE	XX
MAX CREDITS	XX
COINS PER BILL	XX

CURRENT PRICING SUBMENU

Select "SHOW CURRENT" at the Pricing Menu. The following definitions clarify the adjustments in the Pricing menus...

SCREEN TERM	DEFINITION
Slot or Bill Units	Inserted coins and bills accumulate units. This adjustment specifies the quantity of units given for each coin or bill in each position ("unit" is an arbitrary term).
Units per Credit	This number establishes the value of each credit for pricing calculations.
Units per Bonus	Units awarded after a player has accumulated enough points for a bonus.
Minimum Units	No credits will be awarded until this many coin or bill units have accumulated.
Credits to Start	Credits needed to begin game play. This sets the basic cost per game.
Credits to Continue	Credits required to continue a game which is already in progress.
Maximum Credits	Sets limits on the number of credits that the game will accept.
Coins per Bill	Establishes value for bills by comparing them to an equivalent number of coins.

STANDARD PRICING TABLE

NAME	START	CONTINUE	CREDITS/COIN	COIN 1	COIN 2	COIN 3	COIN 4	BILL
USA1	2	2	1/25¢	.25¢	.25¢			\$1.00
USA2	2	1	1/25¢	.25¢	.25¢			\$1.00
USA3	1	1	1/25¢	.25¢	.25¢			\$1.00
USA4	1	1	1/50¢, 3/\$1.00	.25¢	.25¢			\$1.00
USA5	2	1	1/50¢, 4/\$1.00	.25¢	.25¢			\$1.00
USA6	1	1	1/50¢	.25¢	.25¢			\$1.00
USA7	1	1	1/50¢, 3/\$1.00	.25¢	.25¢			\$1.00
USA8	2	2	1/50¢, 4/\$1.00	.25¢	.25¢			\$1.00
USA9	3	2	1/25¢, 4/\$1.00	.25¢	.25¢			\$1.00
USA10	3	3	1/25¢, 4/\$1.00	.25¢	.25¢			\$1.00
USA ECA	3	3	1/25¢, 4/\$1.00	\$1.00	.25¢	.10¢	.05¢	\$1.00
GERMANY1	2	2	1/1DM, 6/5DM	1DM	5DM			
GERMANY2	2	1	1/1DM, 7/5DM	1DM	5DM			
GERMANY3	2	1	1/1DM, 8/5DM	1DM	5DM			
GERMANY4	2	1	1/1DM, 5/5DM	1DM	5DM			
GERMANY5	2	1	1/1DM, 6/5DM	1DM	5DM			
GERMANY ECA	2	2	1/1DM, 2/2DM, 6/5DM	5DM	2DM	1DM		
FRANCE1	2	2	2/5Fr, 5/10Fr	5Fr	10Fr			
FRANCE2	2	1	2/5Fr, 4/10Fr	5Fr	10Fr			
FRANCE3	2	1	1/5Fr, 3/10Fr	5Fr	10Fr			
FRANCE4	2	1	1/5Fr, 2/10Fr	5Fr	10Fr			
FRANCE5	2	1	2/5Fr, 5/10Fr, 11/2 X 10Fr	5Fr	10Fr			
FRANCE6	2	1	2/5Fr, 4/10Fr, 9/2 X 10Fr	5Fr	10Fr			
FRANCE7	2	1	1/5Fr, 3/10Fr, 7/2 X 10Fr	5Fr	10Fr			
FRANCE8	2	1	1/5Fr, 2/10Fr, 5/2 X 10Fr	5Fr	10Fr			
FRANCE9	2	1	1/3 X 1Fr, 2/5Fr	1Fr	5Fr			
FRANCE10	2	1	1/2 X 1Fr, 3/5Fr	1Fr	5Fr			
FRANCE11	2	1	1/3 X 1Fr, 2/5Fr, 5/2 X 5Fr	1Fr	5Fr			
FRANCE12	2	1	1/2 X 1Fr, 3/5Fr, 7/2 X 5Fr	1Fr	5Fr			
FRANCE ECA	2	2	1/3 X 1Fr, 2/5Fr, 5/2 X 5Fr	1Fr	5Fr	10Fr	20Fr	
CANADA	2	2	1/\$1.00, 2/\$2.00	\$1.00	\$2.00			\$1.00
SWISS1	2	2	1/1SFr, 6/5SFr	1SFr	5SFr			
SWISS2	2	2	1/1SFr, 7/5SFr	1SFr	5SFr			
SWISS3	2	2	1/1SFr, 8/5SFr	1SFr	5SFr			
ITALY	2	2	1/500Lit	500Lit	500Lit			
UK ECA1	1	1	1/50p, 3/£1.00	£1.00	50p	20p	10p	
UK ECA2	1	1	1/50p, 2/£1.00	£1.00	50p	20p	10p	
UK ECA3	1	1	1/30p, 2/50Pta, 5/£1.00	£1.00	50p	20p	10p	
UK4	1	1	1/50p, 3/£1.00	£1.00	50p			
UK5	1	1	1/50p, 2/£1.00	£1.00	50p			
SPAIN1	2	2	1/100Pta, 6/500Pta	100Pta	500Pta			
SPAIN2	2	2	1/100Pta, 5/500Pta	100Pta	500Pta			
AUSTRALIA1	2	2	1/3X20¢, 2/\$1.00	.20¢	\$1.00			
AUSTRALIA2	2	2	1/5X20¢, 1/\$1.00	.20¢	\$1.00			
JAPAN1	2	2	1/100Yen	100 Yen	100 Yen			
JAPAN2	2	2	2/100Yen	100 Yen	100 Yen			
AUSTRIA1	2	2	1/5Sch, 2/10Sch	5 Sch	10 Sch			
AUSTRIA2	2	2	1/2X5Sch, 3/2X10Sch	5 Sch	10 Sch			
BELGIUM1	2	2	1/20BF	20BF	20BF			
BELGIUM2	2	2	3/20BF	20BF	20BF			
BELGIUM3	2	2	2/20BF	20BF	20BF			
BELGIUM ECA	2	2	1/20BF	50BF	20BF	5BF		
SWEDEN	2	2	1/3X1SKr, 2/5SKr	1SKr	5SKr			
NEW ZEALAND1	1	1	1/3X20¢	20¢	20¢			
NEW ZEALAND2	1	1	1/2X20¢	20¢	20¢			
NETHERLANDS	2	2	1/1HFI, 3/2.5HFI	1HFI	2.5HFI			
FINLAND	2	2	1/1Fmk	1Fmk	1Fmk			
NORWAY	2	2	1/2X1NKr, 3/5X1NKr	1NKr	1NKr			
DENMARK	2	2	1/2X1DKr, 3/5DKr, 7/2X5DKr	1DKr	5DKr			
ANTILLIES	2	2	1/25¢, 4/1G	.25¢	1G			
HUNGARY	2	2	1/2X10Ft, 3/2X20Ft	10Ft	20Ft			

ADDITIONAL ADJUSTMENTS

Select "ADDITIONAL ADJUSTMENTS" at the Adjustments Menu. Additional Adjustments menu items allow you to set the game to match player requirements. These adjustments affect speed, challenge, rewards, etc. that determine player enjoyment.

Highlight a line item with the middle two control buttons inside the coin door. Select the option with the right control button.

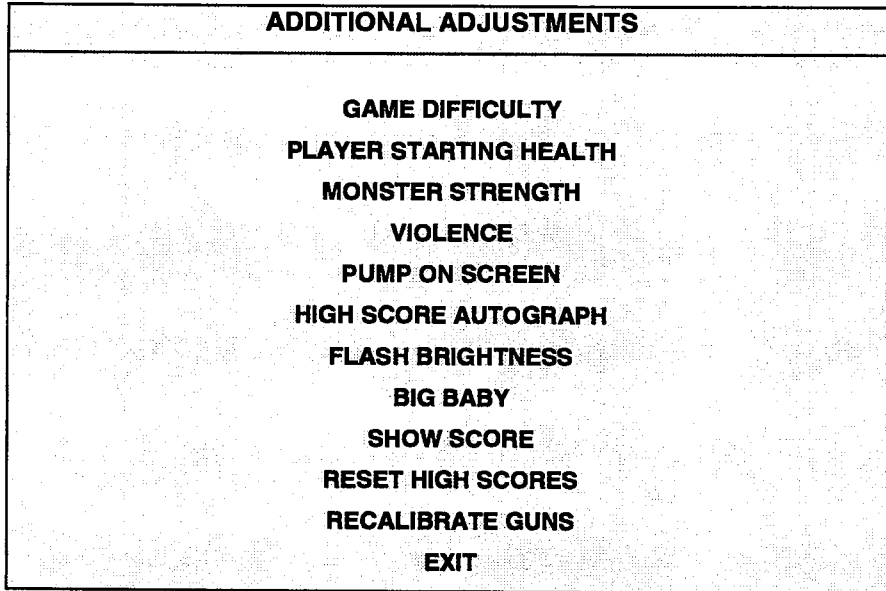

ADDITIONAL ADJUSTMENTS SUBMENU

Game Difficulty has several levels. Choose the level that most closely matches the skills of the players.

Player Starting Health and **Monster Strength** affect game difficulty. Game difficulty, in turn, determines total game time.

High Score Autograph and **Show Score** provide incentives to good players.

Violence is an operator-programmable variable. You may remove it from the game without affecting other game play characteristics.

Pump on Screen affects game difficulty and game time. Enable Pump on Screen to allow the player to use the pump to reload.

Flash Brightness affects gun operation. This is the same setting as FLASH BRIGHTNESS on the Gun Test. (See the Adjustments Menu.) If you set flash brightness too low, the guns may not operate. If set too high, flash brightness might irritate players or reduce monitor life. This adjustment's range is .01 to .99. For new CRTs, the recommended setting is .50. Increase flash brightness by repeatedly pressing PLAYER 2 START. Decrease flash brightness by repeatedly pressing PLAYER 1 START. Save your setting and exit the Gun Calibration screen by pressing CREDIT or TEST MODE. When you exit this screen, the system also saves your other gun calibration settings.

Big Baby is an optional game enemy. You may remove the baby from the game without affecting other game play characteristics.

Reset High Scores allows you to clear the high score table.

Recalibrate Guns assists you in restoring shotgun accuracy to original software performance. Details on use appear later in this chapter.

DIAGNOSTICS

Select "DIAGNOSTICS" at the CarnEvil Main Menu. Diagnostic tests allow you to verify the condition of the electrical and electronic hardware in the game.

Open the coin door. Use four control pushbuttons inside the control section of the cabinet to choose line items. Each line item is the title of a submenu. The leftmost button (SERVICE CREDITS) recalls the previous menu. The second-left button (VOLUME DOWN) moves the item highlight bar upward. The second-right button (VOLUME UP) moves the item highlight bar downward. The rightmost button (TEST MODE) calls up a submenu. The screen displays this submenu. Use the same steps to activate any one of the line items listed.

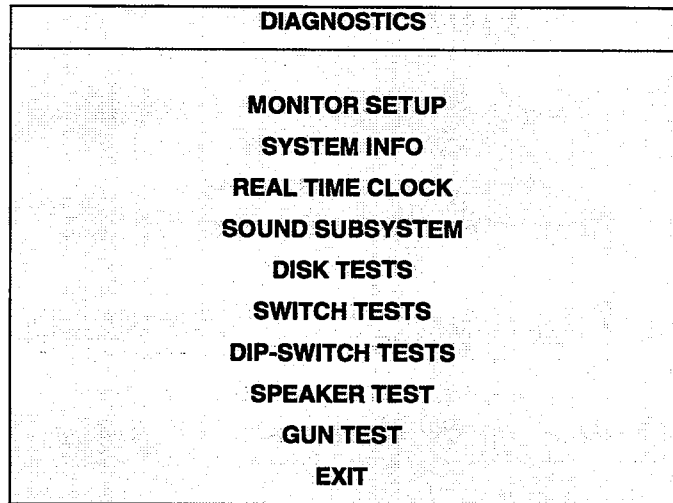

DIAGNOSTICS SUBMENU

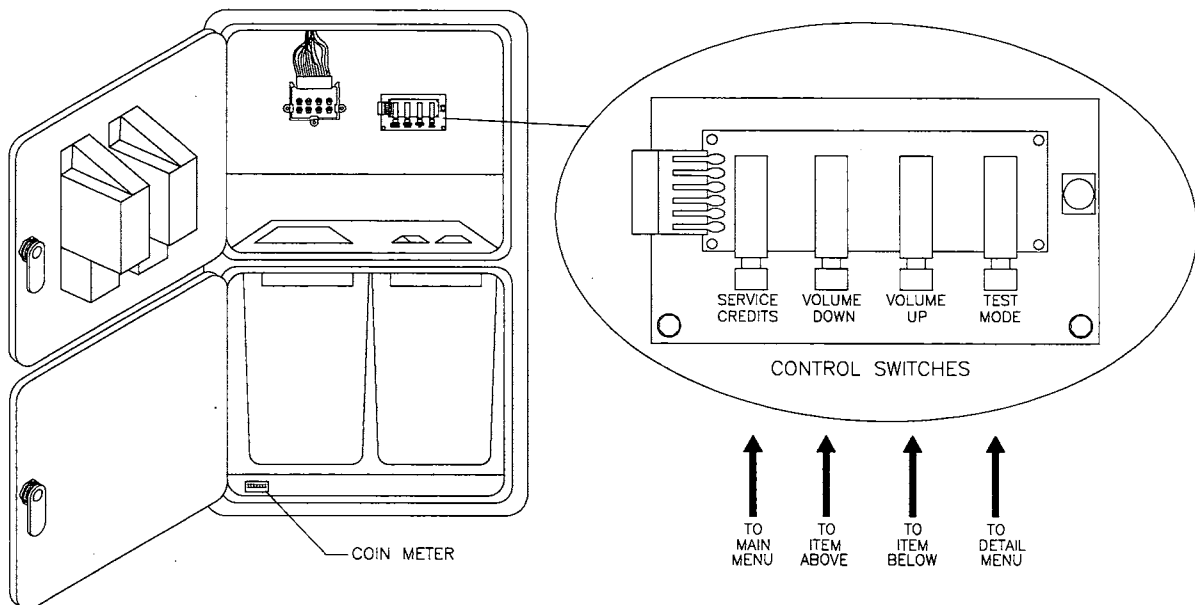

MONITOR SETUP

Select "MONITOR SETUP" at the Diagnostics Menu. The Monitor Patterns routine provides test screens to verify monitor performance or make adjustments.

Highlight a test with the middle two control buttons inside the coin door. Select the option with the right control button.

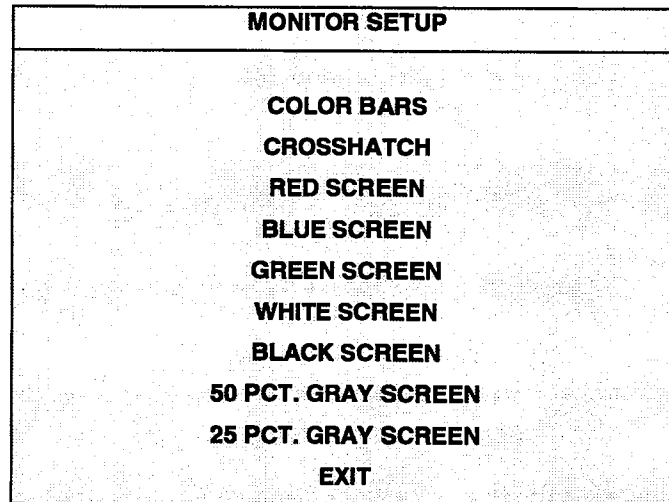

MONITOR SETUP SUBMENU

Color Bars fills the screen with colored stripes. Use the color bars to help you to check or adjust monitor brightness and contrast. The color bars also expose defects in horizontal linearity. Each color bar consists of 32 intensity levels. On a properly adjusted monitor, the top 31 of these levels are visible. Each bar should appear sharp, clear, and distinct from bars on either side. Incorrect adjustment can cause missing detail at the top or bottom of a bar. Bent bars indicate horizontal linearity flaws, such as pie crust, pincushion or barrel distortion. (*Correct color bar colors, left to right: Red, Green, Blue, Black, White, Cyan, Yellow, Violet.*) Set controls as follows: 1. Adjust BRIGHTNESS and CONTRAST to minimum. 2. Turn up BRIGHTNESS until the pixels in the black stripe begin to glow (turn dark gray). 3. Bring up the CONTRAST control until you can see 31 bars.

Crosshatch Patterns fill the screen with a grid and a series of dots. Crosshatch Patterns help you to check or adjust several monitor parameters: These include convergence, linearity, active viewing area and dynamic focus. The grid and the dots should be all white in color, with no fringes or parallel images. The lines should be straight and the dots round. For more detail on these adjustments, consult service literature from the monitor manufacturer.

Color Screen tests fill the screen with 100% of the chosen color at normal intensity. The Color Screen tests help you to check or adjust monitor intensity, black level, blanking and color purity. Each screen should be absolutely uniform from top to bottom and side to side. No retrace lines or noise should be visible. Color Screens may not hold their uniformity if the monitor degaussing circuit is defective.

White, Gray, and Black Screens fill the screen with black, gray or white at various intensities. These monochrome screens help you to check or adjust monitor convergence, purity, contrast and intensity. These screens also simplify black level and color gun control settings. The screens should be uniform with no color tints or distortion. No retrace lines or noise should be visible.

If tests indicate a need for adjustment, use controls on the Monitor Remote Adjustment Board.

SYSTEM INFORMATION

Select "SYSTEM INFO" at the Diagnostics Menu. The System Information Menu provides the current version numbers of this game's hardware and software. Use these numbers to describe the system during parts replacement, service calls, etc.

Highlight a test with the middle two control buttons inside the coin door. Select the option with the right control button.

SYSTEM INFORMATION
<p>MIDWAY GAMES, INC. SEATTLE SYSTEM</p> <p>SERIAL NUMBER: XXXXXXXXX GAME: CARNEVIL DATE OF MANUFACTURE: XX/XX/XX</p> <p>PRESS CREDIT OR TEST TO EXIT</p>

SYSTEM INFORMATION SUBMENU

The System Information screen reports information but does not permit you to make changes. The Title line identifies the manufacturer of this game and the electronic board set used in this product. The Serial Number, Game, and Date of Manufacture identify the game name and production run.

REAL TIME CLOCK

The game's real-time clock provides the current date and time. This screen also allows you to adjust the clock. You may adjust for time zone changes, clock resets, backup battery replacements, etc.

Highlight a test with the middle two control buttons inside the coin door. Select the option with the right control button.

REAL TIME CLOCK
<p>DISPLAY SET</p> <p>EXIT</p>

REAL TIME CLOCK SUBMENU

The real-time clock provides accurate, time-stamped game statistics. The clock does not affect game operation. Once set, the clock runs until the battery fails, or service or some major fault disrupts circuits. Periodically examine the top lines of the SELF TEST screen for the correct time and date.

SOUND SUBSYSTEM TEST

Select "SOUND SUBSYSTEM" at the Diagnostics Menu. Sound Subsystem Tests verify that audio components are connected and operate properly.

Highlight a test with the middle two control buttons inside the coin door. Select the option with the right control button.



NOTICE: To test the speakers thoroughly, increase the volume level. Check the volume setting before testing. Before returning to Game-Over Mode, reset the volume level to its original setting.

SOUND SUBSYSTEM TEST
BOOT VERSION: XX.XX
SDRC VERSION: XX.XX
PORT STATUS: GOOD
CHECKSUM: XXXX
SRAM: OK
DRAM: OK
TONE STATUS: GOOD
OS VERSION: XX.XX
PRESS CREDIT OR TEST TO EXIT

SOUND SUBSYSTEM SUBMENU

Version, Status, Checksum, and RAM Reports are diagnostic routines. These routines analyze the digital sound circuits, and can detect sound memory problems. Test results appear as numbers or messages. Sounds may also accompany some tests. Reports other than GOOD or OK indicate a problem.

DISK TESTS

Select "DISK TESTS" at the Diagnostics Menu. Disk Tests allow you to verify proper operation of the hard disk drive assembly.

Highlight a test with the middle two control buttons inside the coin door. Select the option with the right control button.

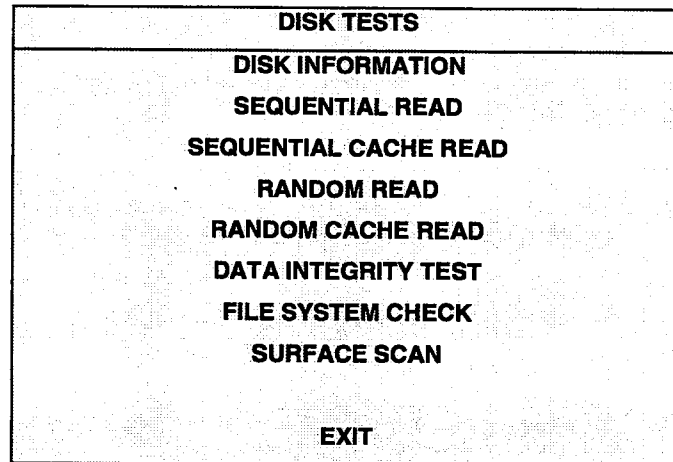

DISK TESTS SUBMENU

Disk Information

The Disk Information routine verifies the interface between the CPU Board Assembly and hard disk drive. The processor requests disk information. Data cannot be retrieved successfully if there is a problem.

Sequential Disk Read

This routine tries to access every bit of data in the order it is stored directly on the disk. The hard disk drive media may be defective if this routine cannot be completed successfully.

Sequential Cache Read

This routine tries to access every bit of data in the order it is stored in the temporary disk memory cache. If this test is not successful, the memory circuits may be faulty.

Random Disk Read

This routine tries to access every bit of data in no particular order directly from the disk. This test may detect problems with ability to position the drive heads accurately over the requested data.

Random Cache Read

This routine tries to access every bit of data in no particular order from the temporary disk memory cache. If the cache fails this test, memory circuits may contain a fault.

Data Integrity Test

This test analyzes the data on the disk drive. The test determines if corrupted data is on the disk. Bad data can cause the program to falter even though the hard disk operates correctly.

File System Check

This routine performs a file-by-file check of the data stored on the hard disk.

Surface Scan

The magnetic material on the disk can become damaged, causing data to be unreadable. This routine locates unusable areas on the disk and marks them for future reference.

SWITCH TESTS

Select "SWITCH TESTS" at the Diagnostics Menu. Switch Tests verify proper operation of the game's switches, including buttons and shotgun switches.

Activate each switch, and the indicator on the screen changes state. Release the switch and the indicator returns to its previous, normally open or closed condition. Switches may be tested in any combination. To exit the test, simultaneously press the middle two control buttons inside the coin door. The Switch Test Screen refers to these buttons as "volume buttons."

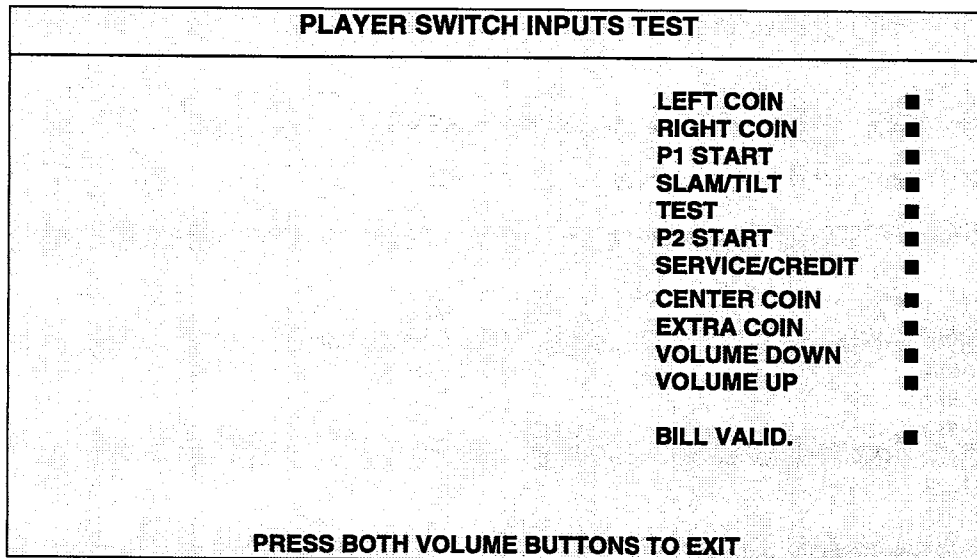

SWITCH TEST SCREEN

Switches appear on the screen as colored boxes. Red boxes indicate an open state. Green indicates closed. Any other color indicates a fault condition. A single indication on the menu screen should exactly duplicate a button or shotgun change. You'll notice a unique number for a switch recognized by game electronics.

Use Player Controls Tests to verify crossed wires, intermittent conditions, and stuck switches.

	NOTICE: Some switches may not be used with this game. If you can't find one of the listed switches, check the wiring diagram.
---	--

DIP-SWITCH TESTS

Select "DIP-SWITCH TESTS" at the Diagnostics Menu. Two 8-position DIP switch banks reside on the CPU Board. DIP-Switch Tests allow you to check the position of the 16 switches in these banks. You can change the setting of any DIP switch without removing the CPU cover.

Highlight a test with the middle two control buttons inside the coin door. Select the option with the right control button. The screen displays an illustration of each switch block and the current settings.

You can change DIP-switch positions with power on. Set any switch, and then check the screen to verify that the new setting is enabled. Country switch settings have no effect if the CMOS Coinage Control is set to On.

Refer to the charts for assistance in choosing switch positions (* indicates factory defaults). To exit the DIP-switch Test, press the left control button (inside the coin door).

DIP Switch 1 (U9)				SW1	SW2	SW3	SW4	SW5	SW6	SW7	SW8
Coinage Control	DIPSwitch CMOS			Off On*							
USA1	Ger1	Fr1	UK1		Off*	Off*	Off*				
USA2	Ger2	Fr2	UK2		On	Off	Off				
USA3	Ger3	Fr3	UK3		Off	On	Off				
USA4	Ger4	Fr4	UK4		On	On	Off				
USA5	Ger5	Fr5	UK5		Off	Off	On				
USA6	Ger6	Fr6	UK6		On	Off	On				
USA7	Ger7	Fr7	UK ECA		Off	On	On				
USA/Ger/Fr ECA					On	On	On				
Free Play (All Countries)					On	On	On				
USA								Off*	Off*		
France								On	Off		
Germany								Off	On		
United Kingdom*								On	On		
Not Used										Off*	
Not Used										On	
Power Up Test Loop One Time											Off*
Power Up Test Loop Continuous											On

*Except Free Play, which is "on" for SW2 through SW6.

DIP Switch 2 (U8)				SW1	SW2	SW3	SW4	SW5	SW6	SW7	SW8
Not Used				Off*							
Not Used				On							
Not Used					Off*	Off*					
Not Used					On	On					
Graphics Speed 45MHz							On*	On*			
Graphics Speed 47MHz							Off	Off			
Not Used									Off		
Not Used									On*		
Power Up Test Active										Off*	
Power Up Test Bypass										On	
Game Mode											Off*
Test Mode											On

SPEAKER TEST

Select "SPEAKER TEST" at the Diagnostics Menu. The SPEAKER TEST provides audio signals to test the loudspeakers.

Use tests on the Speaker Test menu to verify operation of audio system components. Highlight a test with the middle two control buttons inside the coin door. Select the option with the right control button.

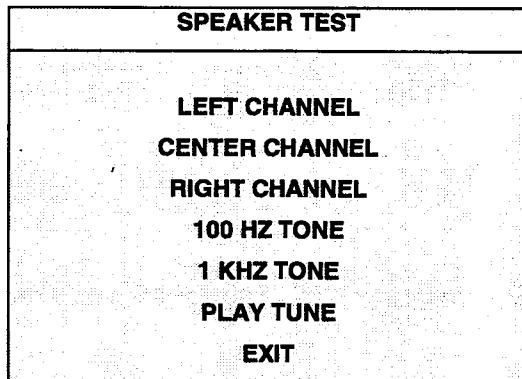

SPEAKER TEST SUB-MENU

The channel subtests use voices to verify speaker locations. Use the 100 Hz tone to check the speakers' base response.

The PLAY TUNE subtest uses game sounds to check that speakers are correctly phased. "Muddy," weak or distorted sound during this test may indicate crossed wires or out-of-phase speaker connections.



NOTICE: Check the volume setting before testing. Increase the volume level to fully test the speakers. Remember to restore the volume to its previous level before returning to Game-Over Mode.

GUN TEST

Select "GUN TEST" at the Diagnostics Menu. The Gun Test allows you to check targeting and basic gun operation. Inaccurate firing discourages players quickly and reduces repeat game play.

	<p>NOTICE: To recalibrate and verify shotgun accuracy, use the "Recalibrate Guns" option on the CarnEvil Main Menu.</p>
---	--

Perform the Gun Test on each shotgun separately. Player 1 shotgun test results appear in green lettering on the screen's left side. Player 2 results appear in purple on the right. Aim a shotgun at the screen. The Targeting subtest indicates when the gun moves on or off the screen. The trigger subtest senses when the triggers opens and closes. The Pump subtest detects when the pump opens and closes.

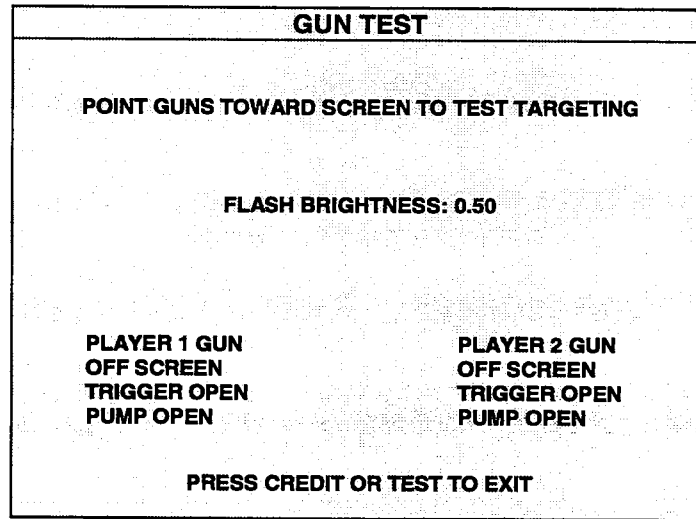

GUN TEST SCREEN

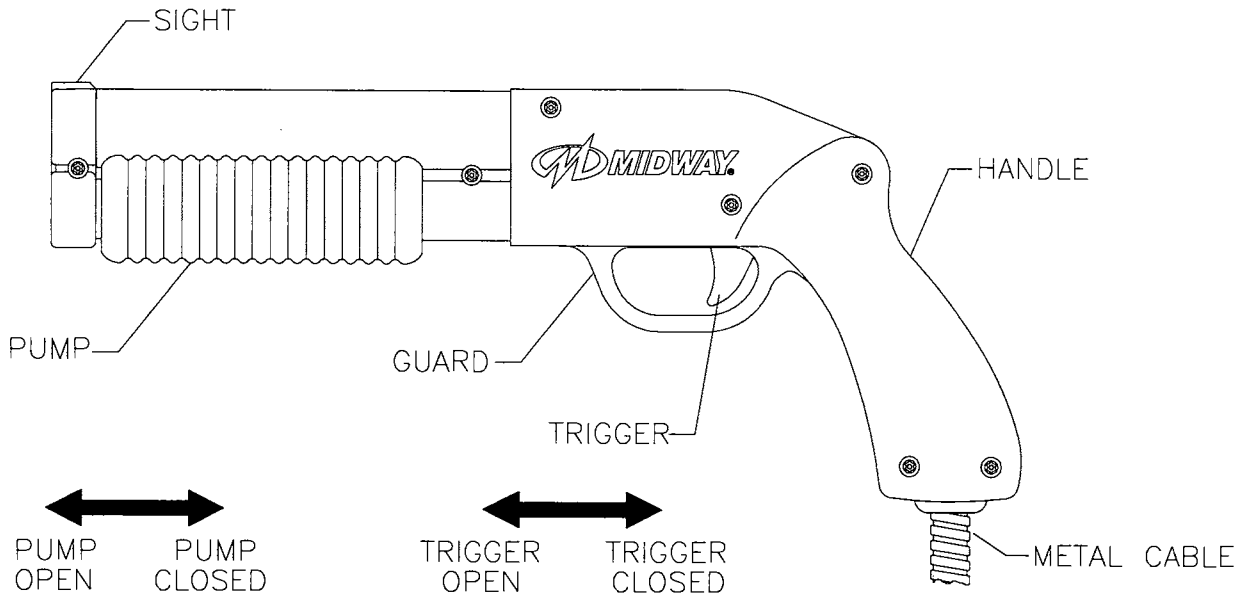

SHOTGUN PARTS

Flash Brightness affects gun operation. This is the same setting as FLASH BRIGHTNESS on the Additional Adjustments Menu. (See the Adjustments Menu. Early versions of game software also refer to the setting as GAMMA.) If you set flash brightness too low, the guns may not operate. If set too high, flash brightness might irritate players or reduce monitor life. This adjustment's range is .01 to .99. For new CRTs, the recommended setting is .50. Increase flash brightness by repeatedly pressing PLAYER 2 START. Decrease flash brightness by repeatedly pressing PLAYER 1 START. Save your setting and exit the Gun Test screen by pressing CREDIT or TEST MODE.

VOLUME LEVEL

Select "VOLUME LEVEL" at the CarnEvil Main Menu. Music plays continuously with the Volume Level screen. Use the volume buttons on the control switch bracket to change the sound level of the game. (These are the middle two buttons, inside the coin door.) Press the right control button to save the volume level and return to the Main Menu.

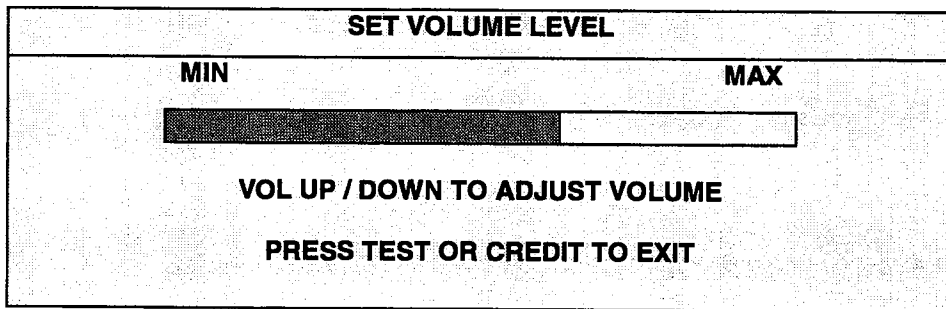

VOLUME LEVEL SCREEN

Loud games attract more player interest than games with low-level sound. The Attract Mode sound level is lower than the game play sound level.

Attract Mode sound can be turned on or off without changing the game volume level (see Adjustments).

	<p>NOTICE: These adjustments affect the volume of tests as well as of game play. If you set volume levels to minimum (zero), the speakers are silent during audio tests. We recommend setting volume levels to a moderately high value whenever you perform sound tests. After you complete tests, you may return sound levels to previous settings.</p>
---	---

UTILITIES

Select "UTILITIES" at the CarnEvil Main Menu. Utilities menu items allow you restore game operation to original software performance. Of course, game performance also depends on the condition of game hardware.

Highlight a line item with the middle two control buttons inside the coin door. Select the option with the right control button.

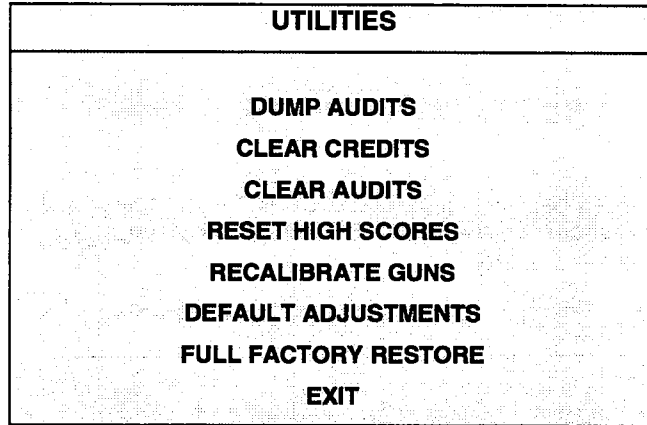

UTILITIES SUBMENU

Dump Audits allows you to replace current audit data with previously saved data.

Clear Credits opens a menu that allows you to zero the game's credit data. Examine and record audit information before you make changes.

Clear Audits opens a menu that allows you to zero the game's audit data.

Reset High Scores permits you to delete player names and scores that appear in the Attract Mode. This feature may be useful if players insert inappropriate language into the high score table.

Recalibrate Guns opens a menu that allows you to fine-tune shotgun accuracy. You should periodically recalibrate and test the shotguns. Players appreciate accurate weapons.

Default Adjustments opens a menu that allows you to reset game adjustments to factory settings.

Full Factory Restore allows you to reset game adjustments and audits to factory settings.

	NOTICE: Be careful when clearing audit information. Once you clear data, you can't restore it.
---	---

CARNEVIL™

SECTION THREE

PARTS



WARNING: USE OF NON-MIDWAY PARTS OR CIRCUIT MODIFICATIONS MAY CAUSE SERIOUS INJURY OR EQUIPMENT DAMAGE! USE ONLY MIDWAY AUTHORIZED PARTS.

For safety and reliability, do not substitute parts or modify MIDWAY products. Substitute parts or modifications may void EMC directive or FCC type acceptance.

CABINET FRONT VIEW AND FRONT HOUSING ASSEMBLY

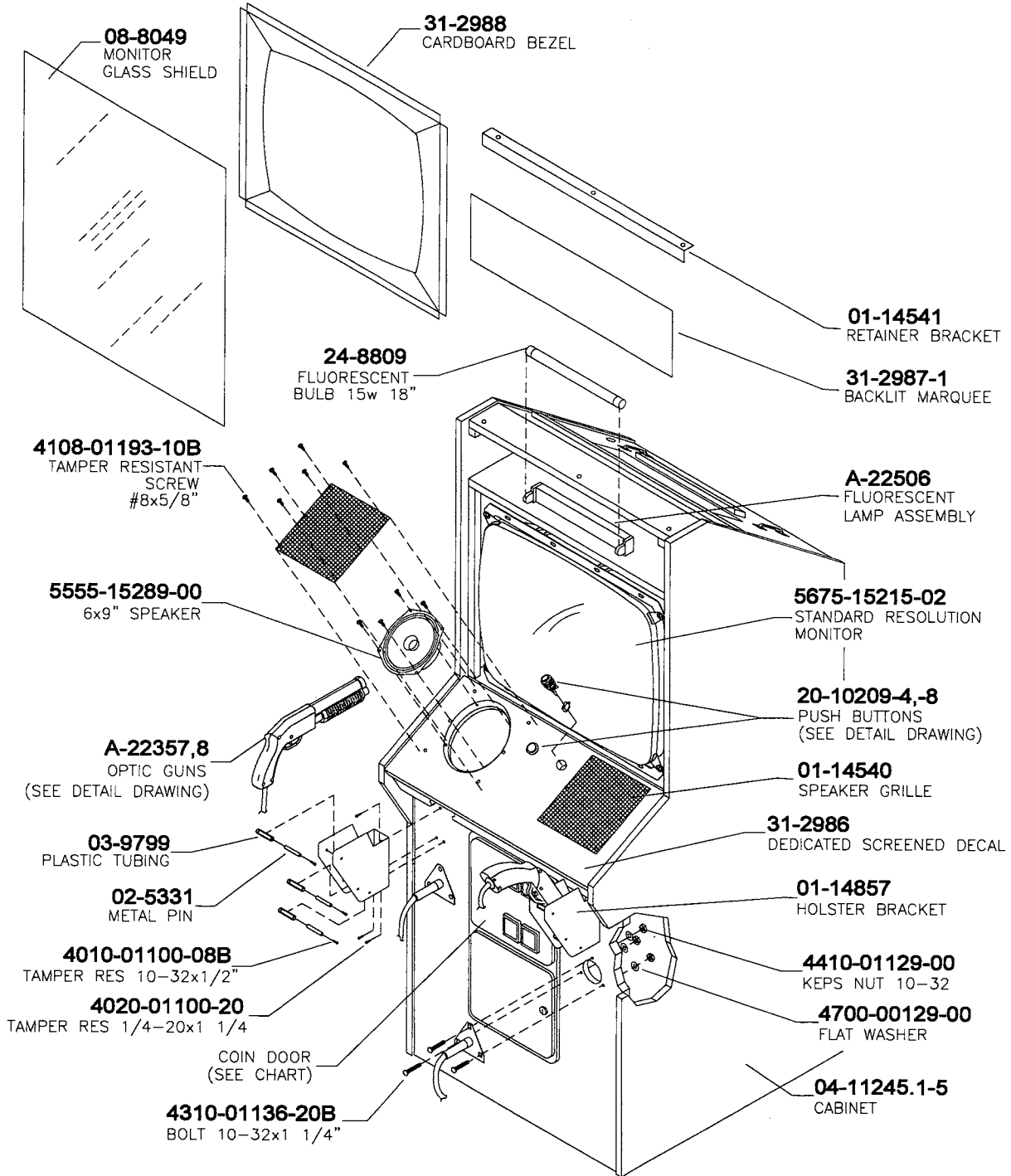

CABINET REAR VIEW

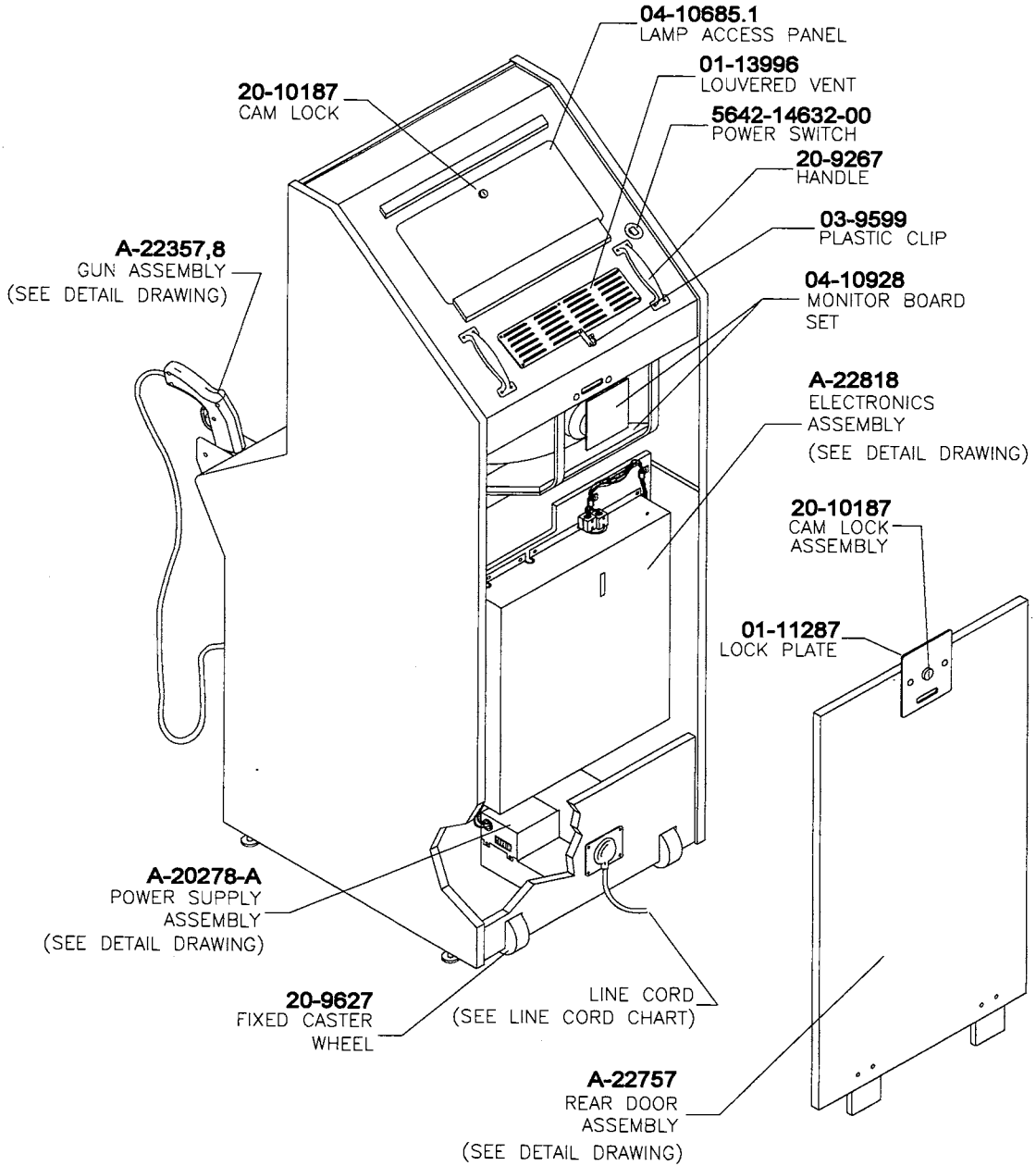

A-22757 REAR DOOR ASSEMBLY

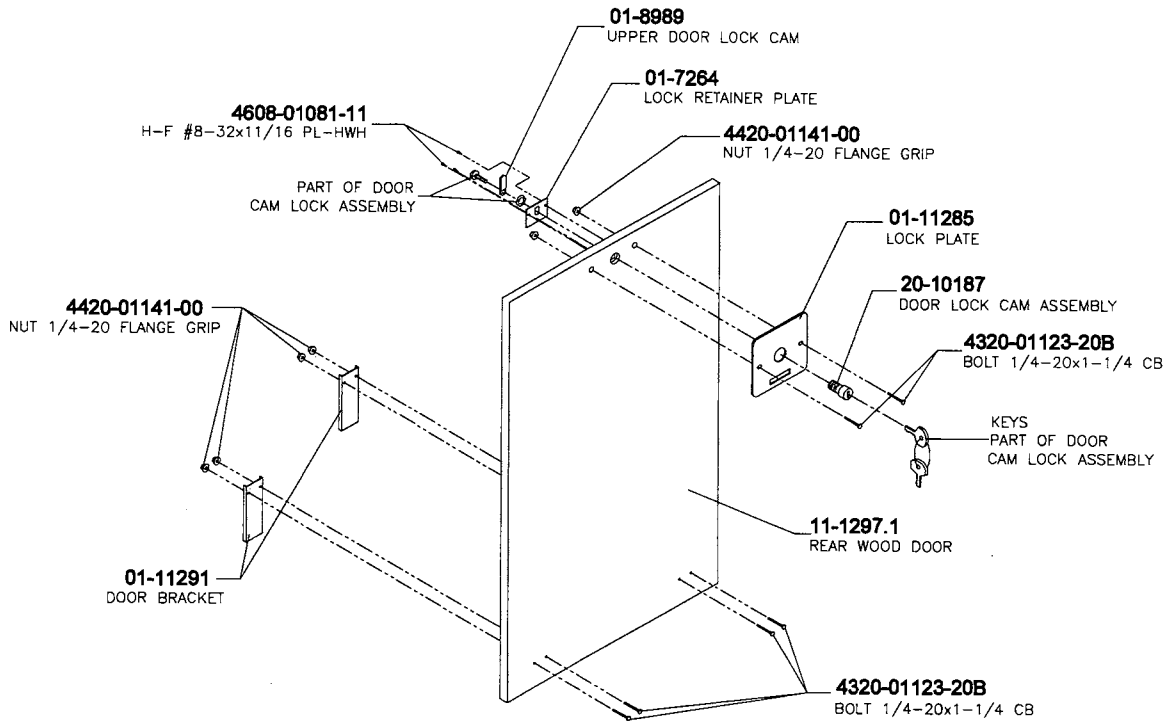

CABINET SHOWN FOR REFERENCE

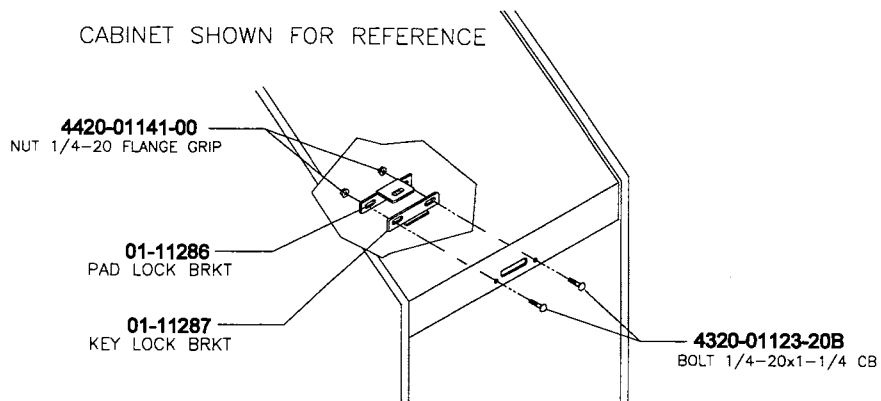

COIN DOOR ASSEMBLY

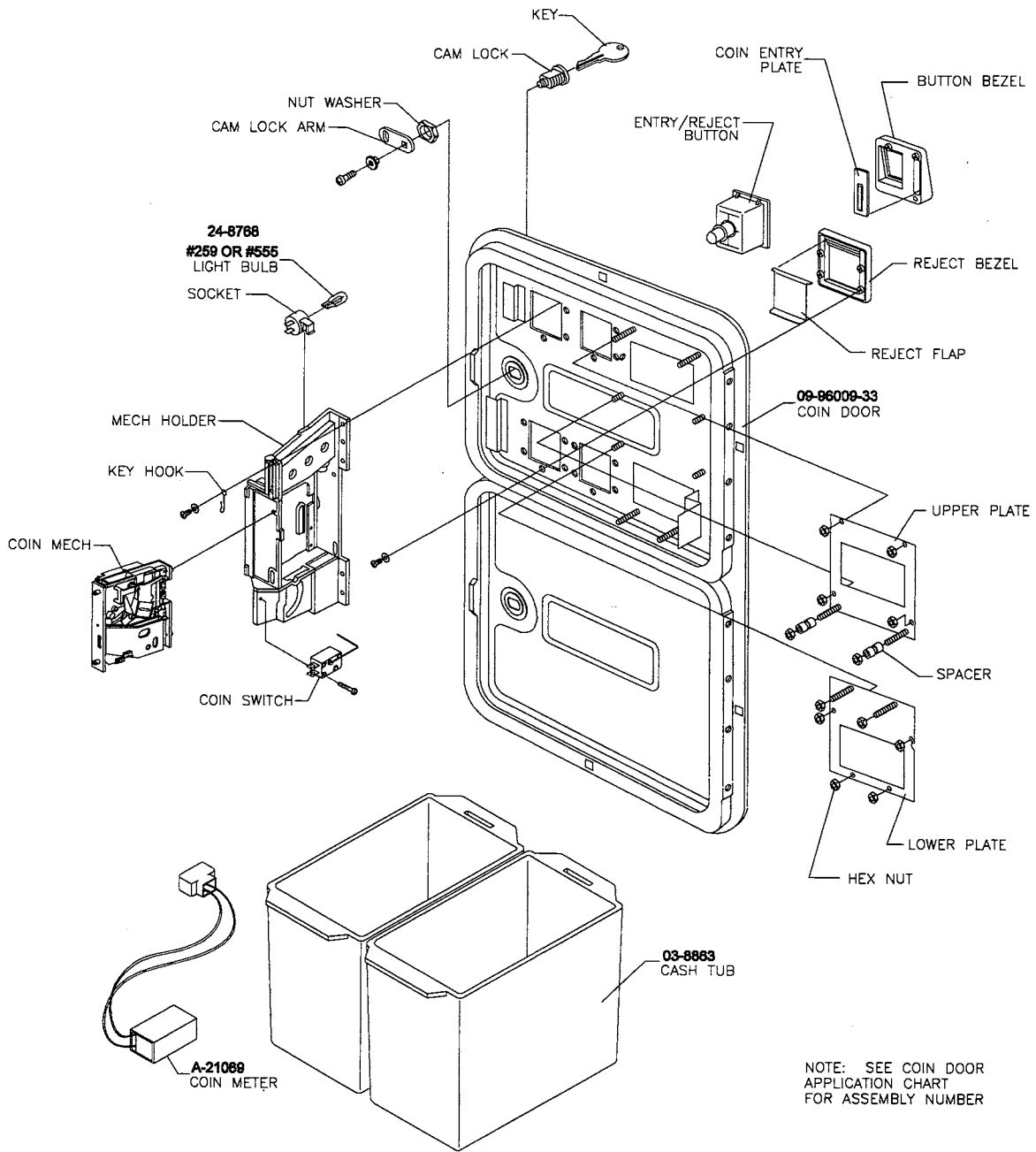

SHOTGUN ASSEMBLY

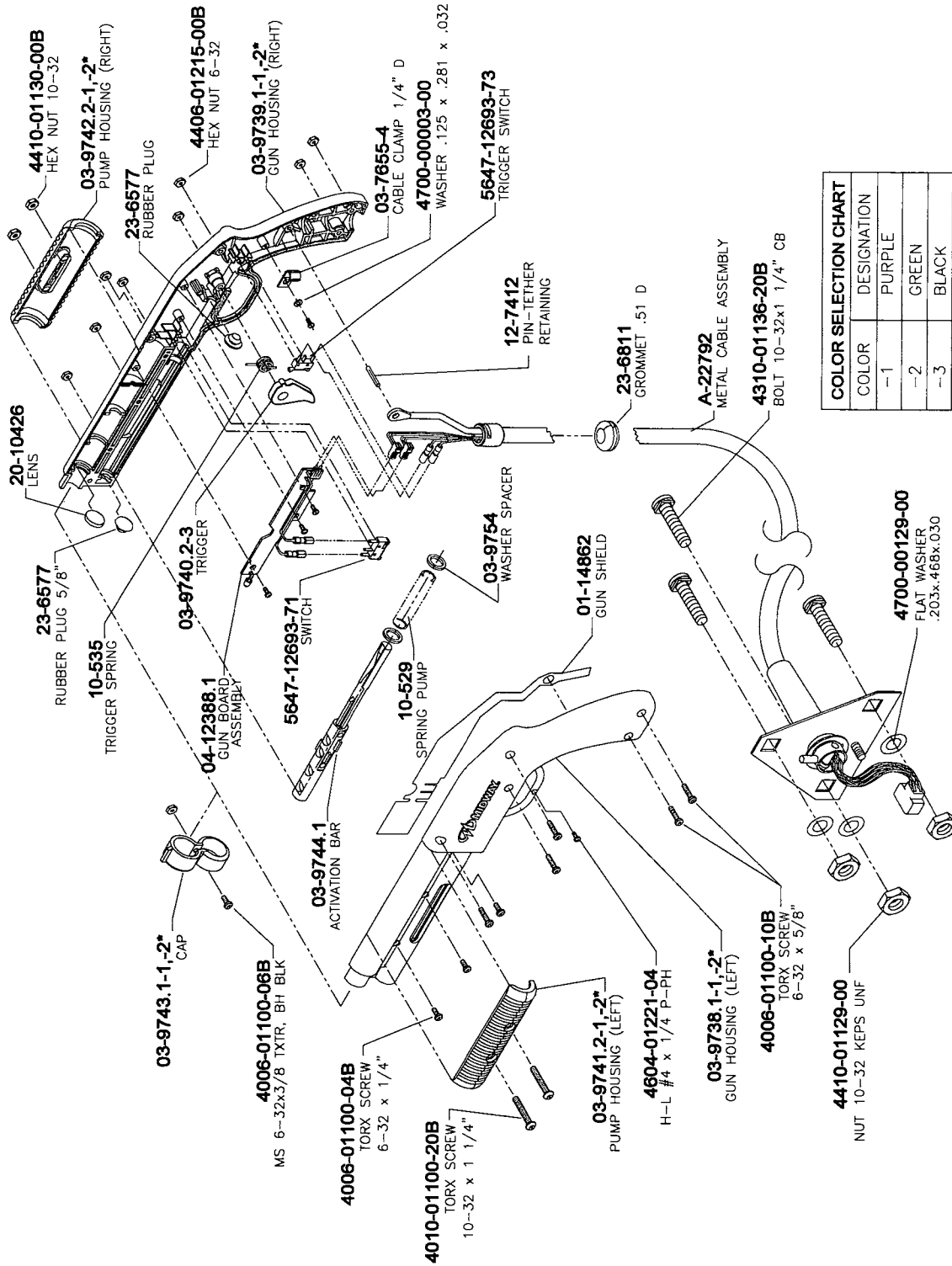

COLOR SELECTION CHART	
COLOR	DESIGNATION
-1	PURPLE
-2	GREEN
-3	BLACK

A-22818 ELECTRONICS ASSEMBLY

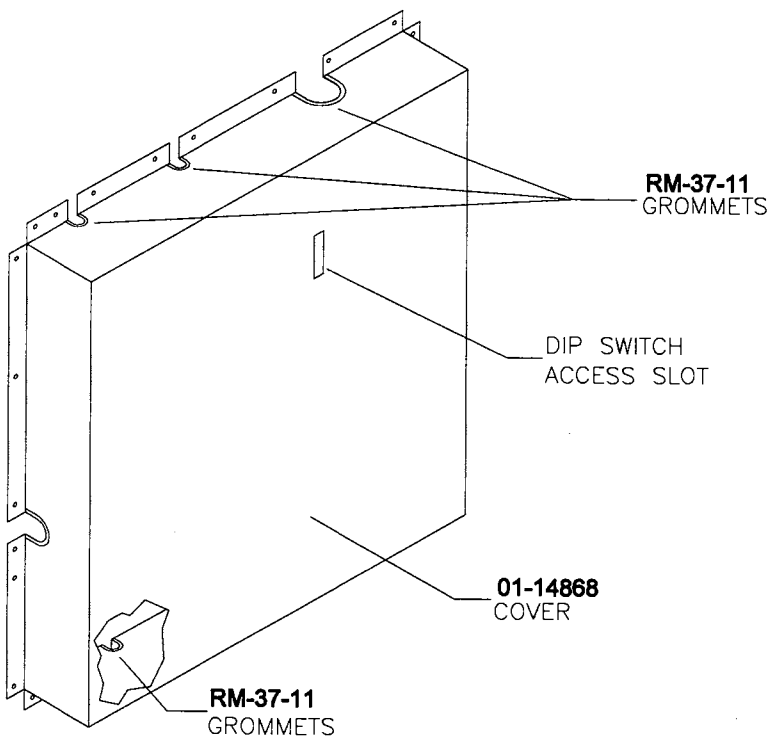
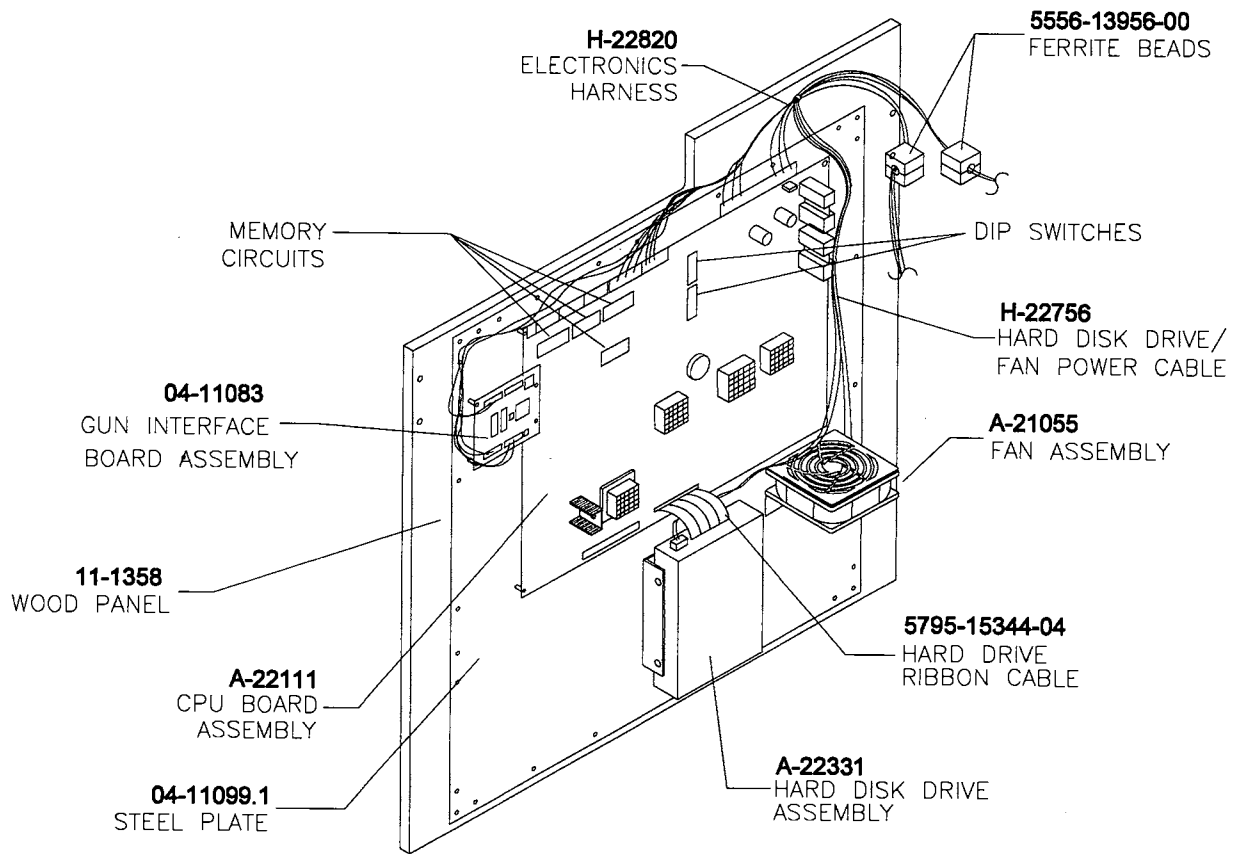

20-10167 POWER SUPPLY ASSEMBLY

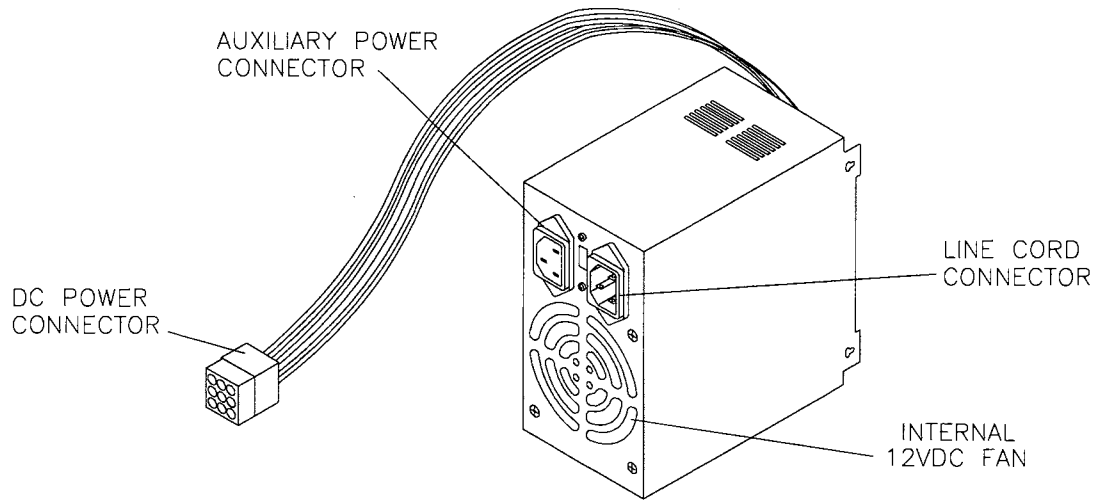

Pin #	Function	Wire Color
1, 2, 3	+5VDC	Red
4, 5, 6	Ground	Black
7	-5VDC	Yellow*
8	+12VDC	Orange*
9	-12VDC	Blue*

***Note:** Many computer grade power supplies use yellow for +12V, blue for -5V, and white for -12V. This is acceptable as long as the pinout is correct.

CPU BOARD ASSEMBLY

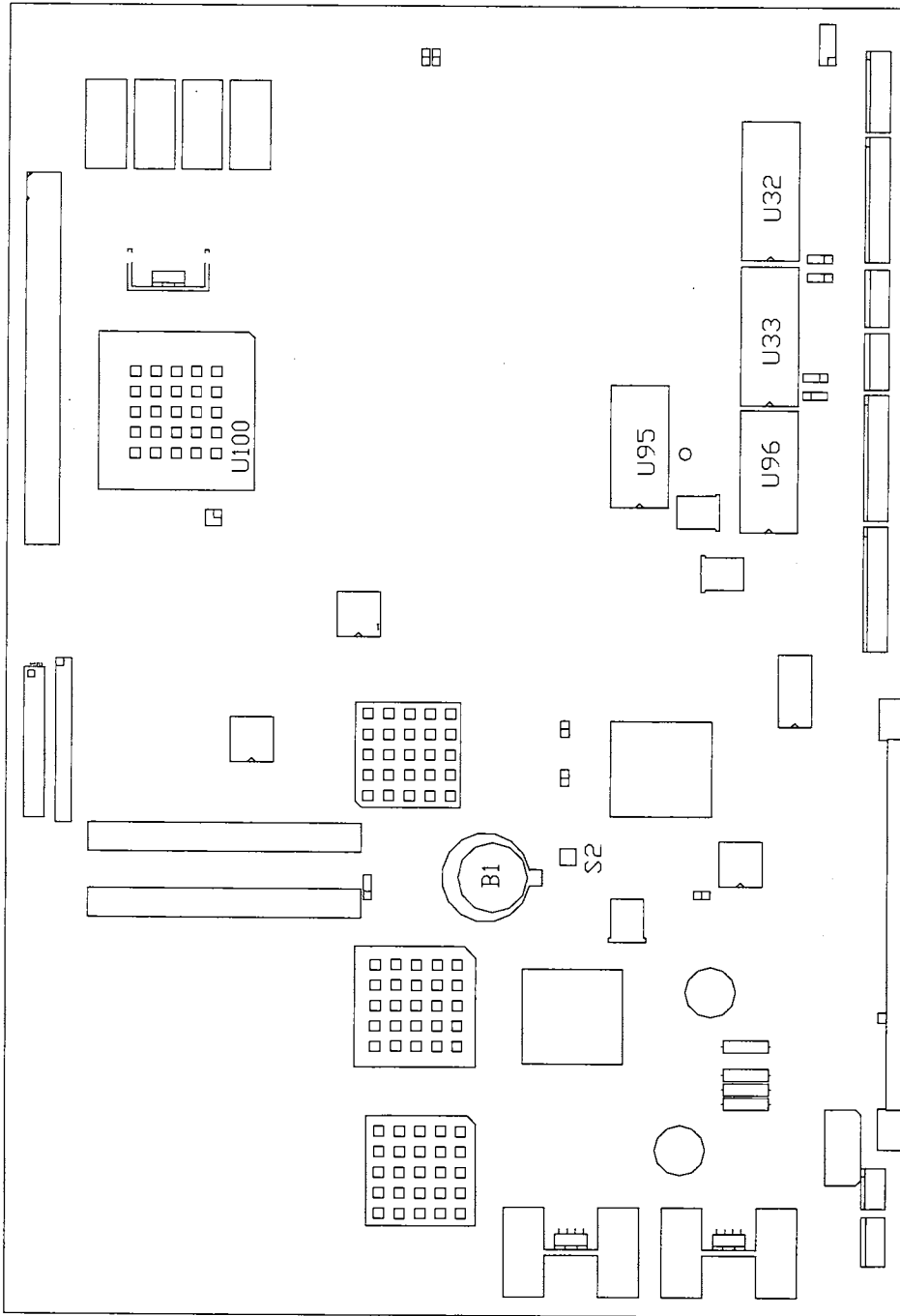

Field Replaceable Parts

Location	Part Number	Function	Description
B1	5880-11056-00	Memory Backup	Battery, 3V Lithium
U32	A-5343-40069-1	CPU Boot ROM	EPROM Assembly
U33	N/A	Boot Expansion ROM	EPROM Assembly
U95	A-5343-40069-2	Sound Boot ROM	EPROM Assembly

GUN CIRCUIT BOARD ASSEMBLY

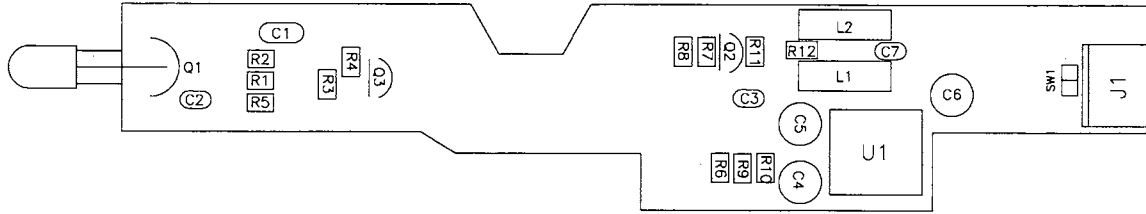

Field Replaceable Parts

Location	Part Number	Function	Description
Q1	5163-15648-00	Light Pickup	Optotransistor
Q2	5190-10270-00	Voltage Amplifier	Transistor, PNP, Type 2N3906
Q3	5160-10269-00	Voltage Amplifier	Transistor, NPN, Type 2N3904
U1	5370-15256-00	Comparator	IC, LM311 Operational Amp

GUN INTERFACE BOARD ASSEMBLY

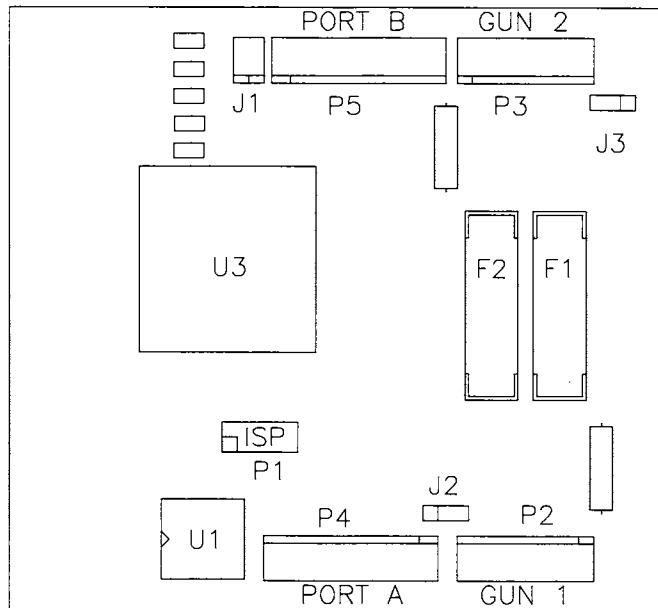

Field Replaceable Parts

Location	Part Number	Function	Description
F1, F2	5735-13840-00	Interface and Gun Circuit Protector	Fuse, 1A, 250V, Fast-Blow, 5 x 20mm

OTHER PARTS

Bulbs, Filters and Fuses

Bulb, Incandescent, 6.3V, #555.....	24-8768
Tube, Fluorescent, 15W, 18".....	24-8809

Cables

Braid, Ground (with Terminal)	H-22327-66
Cable, AC Distribution	H-20279
Cable, 40-Pin Ribbon.....	5795-15344-04
Cable, Hard Disk Drive Power.....	H-22756
Cable, Line Voltage	H-22823
Cable, Main Harness (JAMMA)	H-22820
Cable, Player Panel	H-22769

Documents

Card, Game Information.....	16-10650
Guide, Hard Drive Handling.....	16-10076
Manual, CarnEvil 25"	16-40069-101
Manual, Product Safety	16-10341

Tools

Key, T-10 Torx.....	20-9642
Key, T-20 Torx.....	20-9620
Key, T-27 Torx.....	20-10140

LINE CORD APPLICATION TABLE

Part Number	5850-13275-00	5850-13271-00	5850-13272-00	5850-13273-00	5850-13276-00	5850-13277-00	5850-13278-00
Country							
USA		■					
UK				■			
Italy	■						
Japan							■
New Zealand						■	
Germany			■				
Spain			■				
Denmark			■				
Finland			■				
Holland			■				
Norway			■				
Switzerland					■		
Hungary			■				
Canada		■					
Austria			■				
France			■				
Australia						■	
Belgium			■				

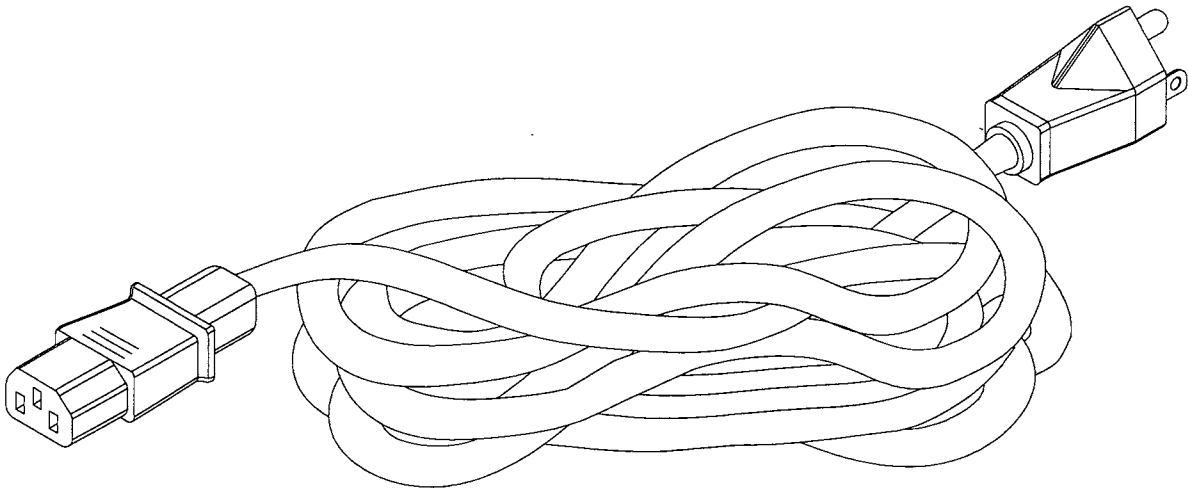

TYPICAL I.E.C. LINE CORD WITH INLINE FEMALE PLUG

COIN DOOR APPLICATION TABLE

Part Number	09-96009-15	09-96009-17	09-96009-22	09-96009-25	09-96009-33	09-96011.1-00 (Electronic)
Country						
USA					■	
UK						■
Italy						■
Japan	■					
New Zealand		■				
Germany						■
Spain						■
Denmark						■
Finland						■
Holland						■
Norway						■
Switzerland						■
Hungary						■
Canada					■	
Austria						■
France						■
Australia						■
Belgium						■

CARNEVIL™

SECTION FOUR

WIRING



WARNING: Failure to reconnect ground wires or replace metal shields and covers with mounting hardware installed and properly tightened may result in radio frequency interference.

JAMMA Table

FUNCTION	WIRE COLOR	PIN	PIN	WIRE COLOR	FUNCTION
Ground	Black	A	1	Black	Ground
Ground	Black	B	2	Black	Ground
+5VDC	Red	C	3	Red	+5VDC
+5VDC	Red	D	4	Red	+5VDC
-5VDC	Yellow	E	5	Yellow	-5VDC
+12VDC	Orange	F	6	Orange	+12VDC
Key	--	H	7	--	Key
Not Connected	--	J	8	Brown	Coin Counter 1
Not Connected	--	K	9	--	Not Connected
Speaker -, Left	Brown-Gray	L	10	Red-Gray	Speaker +, Left
Speaker -, Right	Brown-White	M	11	Red-White	Speaker +, Right
Video Green	Yellow-Green	N	12	Yellow-Red	Video Red
Video Sync	Yellow-White	P	13	Yellow-Blue	Video Blue
Service Credits	White-Gray	R	14	Yellow-Black	Video Ground
Slam Tilt (N/C)	Black-Green	S	15	Black-Blue	Test
Coin 2 Input	Black-Red	T	16	Black-Brown	Coin 1 Input
Player 2 Start	Violet-White	U	17	White	Player 1 Start
Not Connected	--	V	18	--	Not Connected
Not Connected	--	W	19	--	Not Connected
Not Connected	--	X	20	--	Not Connected
Not Connected	--	Y	21	--	Not Connected
Not Connected	--	Z	22	--	Not Connected
Not Connected	--	a	23	--	Not Connected
Not Connected	--	b	24	--	Not Connected
Not Connected	--	c	25	--	Not Connected
Not Connected	--	d	26	--	Not Connected
Ground	Black	e	27	--	Not Connected
Ground	Black	f	28	Black	Ground
SOLDER SIDE			COMPONENT SIDE		

Shotgun Wiring (Not Part of JAMMA Harness)

FUNCTION	WIRE IN GUN	PLAYER 1 WIRE	PLAYER 2 WIRE	GUN CONN.	PANEL CONN.	INTERFACE CONN.
+5VDC	Red	Blue-Red	Gray-Red	1	1	1
Ground	Brown	Blue-Brown	Gray-Brown	2	5	5
Sense	Blue	Blue	Gray-Blue	3	4	4
Reload	Green	Blue-Violet	Gray-Violet	4	7	7
Trigger	White	Blue-White	Gray-White	--	2	2
Ground	Black	Blue-Black	Gray-Black	--	3	3

D.C. Power Source Voltage Limits

FUNCTION	RANGE LIMITS	COLOR	FUNCTION	RANGE LIMITS	COLOR
Digital Circuits	+4.90V to +5.10V	Red	Coin Lights	-4.75V to -5.25V	Yellow
Audio, Lights	+11.5V to +12.5V	Orange	Auxiliary Power	-11.5V to -12.5V	Blue

POWER WIRING DIAGRAM

FUSE APPLICATION CHART	
LINE VOLTAGE	FUSE RATING
120	4A SB 250V
230	2A SB 250V

NOTE: THERE ARE 4 ITEMS THAT MUST BE CHANGED FOR OPERATION ON OTHER LINE VOLTAGES:

1. RATING OF POWER SUPPLY FUSE
2. FLUORESCENT LAMP ASSEMBLY
3. VOLTAGE SWITCH ON POWER SUPPLY
4. A.C. POWER TRANSFORMER

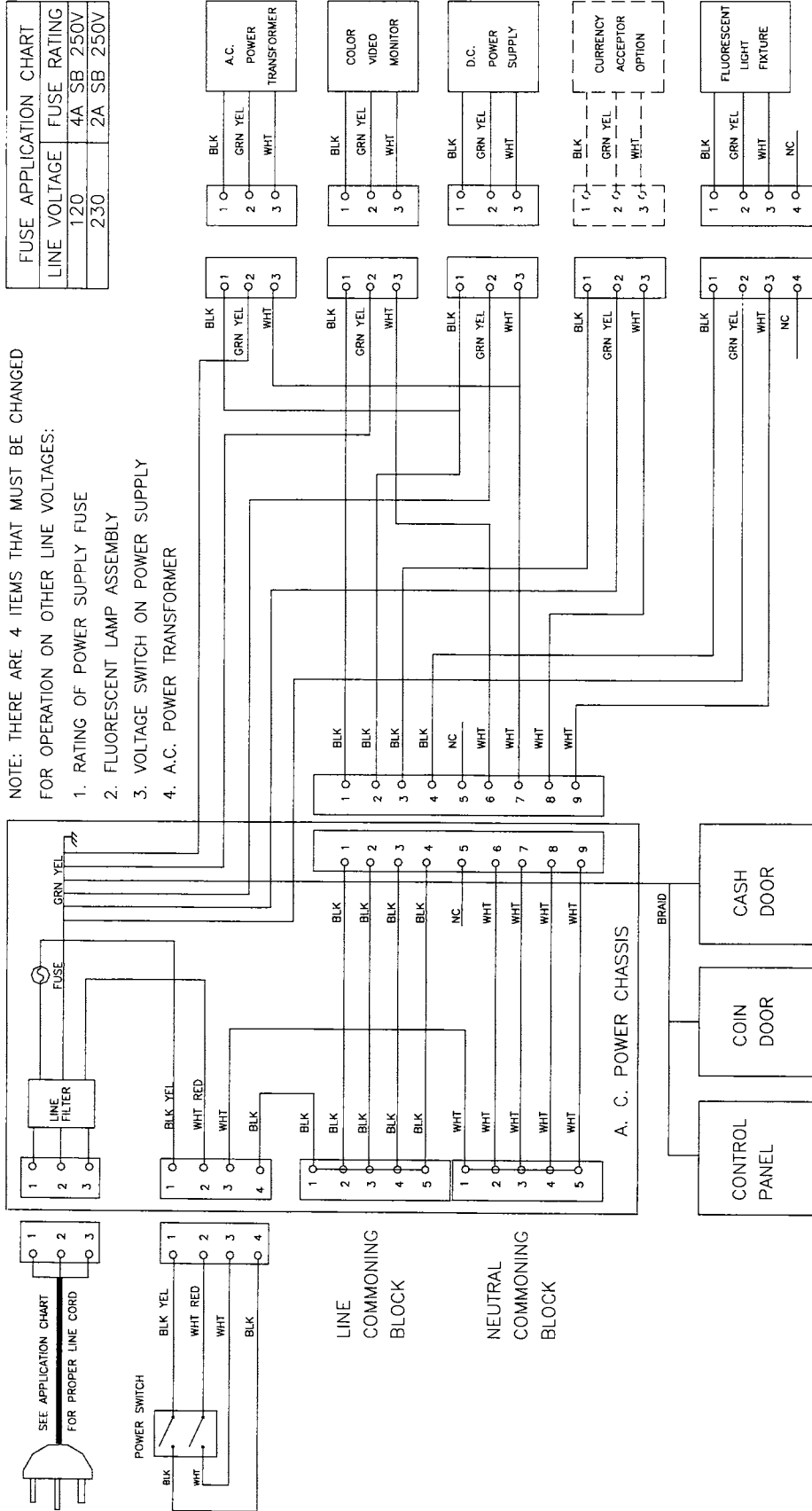

CPU BOARD ASSEMBLY

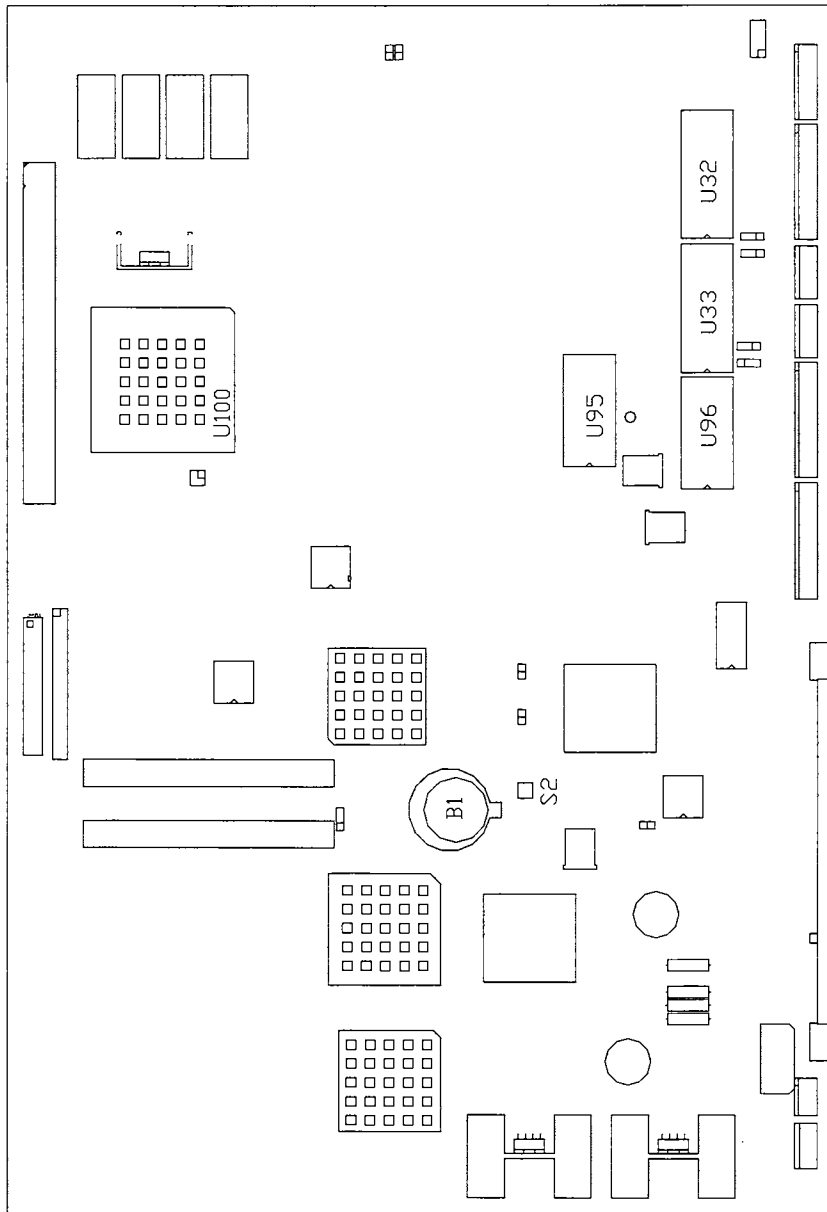

INDICATOR, SWITCH AND JUMPER LOCATIONS

CPU SWITCHES

DESIGNATION	LOCATION	FUNCTION	POSITIONS	STATE	MEANING
S2	MIDDLE CENTER NEAR JAMMA	SETS GAME IN TEST MODE	1	OFF	NORMAL OPERATION
				ON	FORCED TEST MODE

CPU BOARD JUMPER STATUS TABLE

DESIGNATION	LOCATION	FUNCTION	MEANING	SETTING	DEFAULT
J1 (NOTE 1)	MIDDLE CENTER NEAR B1 & S2	REMOTE GAME RESET	RESERVED FOR FUTURE DEVELOPMENT	OPEN	■
				1 & 2	
J2 (NOTE 1)	MIDDLE CENTER NEAR B1 & U86	FUTURE USE ONLY	RESERVED FOR FUTURE DEVELOPMENT	OPEN	
				1 & 2	■
J3 (NOTE 1)	LEFT CENTER NEAR C1 & C589	WATCHDOG CIRCUIT ENABLE	FACTORY DEFAULT SOFTWARE FAIL SAFEGUARD	OPEN	
				1 & 2	■
J4 (NOTE 1)	LEFT CENTER NEAR C11 & C240	FUTURE USE ONLY	RESERVED FOR FUTURE DEVELOPMENT	OPEN	■
				1 & 2	
J5 (NOTE 1)	MIDDLE CENTER NEAR D6 & U64	FUTURE USE ONLY	RESERVED FOR FUTURE DEVELOPMENT	OPEN	■
				1 & 2	
J6 (NOTE 3)	UPPER LEFT NEAR P8 & U32	MAIN BOOT ROM SIZE AND TYPE	CONFIGURES U32 FOR 4 MEGABYTE BOOT ROM	OPEN	
				1 & 2	
J7 (NOTE 3)	UPPER LEFT NEAR P10 & U33	MAIN BOOT ROM SIZE AND TYPE	CONFIGURES U32 FOR 4 MEGABYTE BOOT ROM	OPEN	■
				1 & 2	■
J8 (NOTE 3)	UPPER LEFT NEAR P16 & U33	MAIN BOOT ROM SIZE AND TYPE	CONFIGURES U32 FOR 4 MEGABYTE BOOT ROM	OPEN	
				1 & 2	■
J9 (NOTE 4)	NONE	NOT USED	NONE	NONE	---
J10 (NOTE 5)	UPPER RIGHT NEAR C640 & U14	VIDEO SYNC SIGNAL	NEGATIVE VIDEO SYNC POLARITY	OPEN	■
				1 & 2	
J11 (NOTE 3)	UPPER LEFT NEAR P3 & U33	EXPANSION ROM SIZE AND TYPE	RESERVED FOR FUTURE DEVELOPMENT	OPEN	
				1 & 2	■
J12 (NOTE 4)	NONE	NOT USED	NONE	OPEN	
				1 & 2	
J13 (NOTE 1)	LOWER LEFT NEAR U25 & U100	JTAG PROCESSOR FEATURES	RESERVED FOR FUTURE DEVELOPMENT	OPEN	■
				1 & 2	
P20	UPPER LEFT NEAR P22 & U32	CPU BOARD PRODUCTION TEST JACK	USED FOR FACTORY TEST ONLY	DO NOT USE JUMPERS	---

NOTES:

1. Jumper is not required for any version of this CPU Board. Copper on board completes connections.
2. Jumper is not required for versions 01-05 of this CPU Board. Jump pins 1 & 2 for version 06 and up.
3. Jumper changes for some sizes and types of ROM. Jumper positions shown in ROM kit instructions.
4. Jumper is not required for any version of this CPU Board. These pins are not present on CPU Board.
5. Jumper is not required for production video monitors. Jump pins 1 & 2 for positive sync type monitors.

CPU BOARD LED INDICATOR STATUS TABLE

DESIGNATION	LOCATION	FUNCTION	COLOR	STATE	MEANING
LED 1 (HDD ACT)	BOTTOM CENTER NEAR P15 & P25	HARD DISK ACTIVITY	RED	OFF	DISK DRIVE NOT IN USE
				ON	LOCKED UP (NOTE 1)
				BLINKING	NORMAL OPERATION
LED 2 (HDD INT)	MIDDLE CENTER NEAR B1 & S2	HARD DISK INTERRUPT	RED	OFF	NORMAL OPERATION
				ON	FAULT CONDITION
				BLINKING	WAITING FOR DISK DRIVE (NOTE 2)
LED 3 (VID INT)	MIDDLE CENTER NEAR B1 & S2	VIDEO INTERRUPT	YELLOW	OFF	FAULT CONDITION
				ON	LOCKED UP (NOTE 3)
				BLINKING	NORMAL OPERATION

NOTES:

1. Hard Disk Drive LED 1 only active in short bursts during the game. May appear continuous during startup. If this LED is always on, a fault may have caused the drive to lock up.
2. LED 2 monitors Hard Disk Drive Interrupt requests. May appear irregular. Should not be on continuously.
3. LED 3 monitors Video Circuit Interrupt requests. Interval is very regular. Should not be on continuously.

CPU BOARD LED INDICATOR STATUS TABLE (continued)

DESIGNATION	LOCATION	FUNCTION	COLOR	STATE	MEANING
LED 4 (STATUS)	MIDDLE CENTER NEAR B1 & S2	PROCESSOR STATUS	GREEN	OFF	RESUME USUAL TASK
				ON	SUSPEND TASK (NOTE 4)
				BLINKING	NORMAL OPERATION
LED 5 (IOA)	UPPER CENTER NEAR U8 & U9	PROCESSOR EXCEPTIONS	GREEN	OFF	NO EXCEPTIONS
				ON	EXCEPTION OCCURRING
				BLINKING	FAULT CONDITION (NOTE 5)
LED 6 (SND)	UPPER LEFT NEAR U95 & U101	SOUND ACTIVITY	YELLOW	OFF	NO AUDIO (NOTE 6)
				ON	READING ROM INSTRUCTIONS
				BLINKING	NORMAL OPERATION
LED 7 (+12V)	UPPER RIGHT NEAR C409 & L1	+12V POWER INDICATOR	RED	OFF	NO +12VDC POWER
				ON	NORMAL OPERATION
				BLINKING	POWER FAULT (NOTE 7)
LED 8 (-5V)	UPPER RIGHT NEAR L2 & P4	-5V POWER INDICATOR	RED	OFF	NO -5VDC POWER
				ON	NORMAL OPERATION
				BLINKING	POWER FAULT (NOTE 8)
LED 9 (+5V)	UPPER RIGHT NEAR P14 & R571	+5V POWER INDICATOR	RED	OFF	NO +5VDC POWER
				ON	NORMAL OPERATION
				BLINKING	POWER FAULT (NOTE 9)

NOTES:

4. LED 4 suspensions occur in short bursts during startup. May appear very irregular during circuit reset.
5. LED 5 can blink irregularly during startup. Appears to be on continuously (dimly lit) during game play.
6. LED 6 sound is only active in short bursts during startup. Must be on continuously during game play.
7. LED 7 monitors a regulated power supply voltage source. + 12VDC must be on continuously at all times.
8. LED 8 monitors a regulated power supply voltage source. - 5VDC must be on continuously at all times.
9. LED 9 monitors a regulated power supply voltage source. + 5VDC must be on continuously at all times.

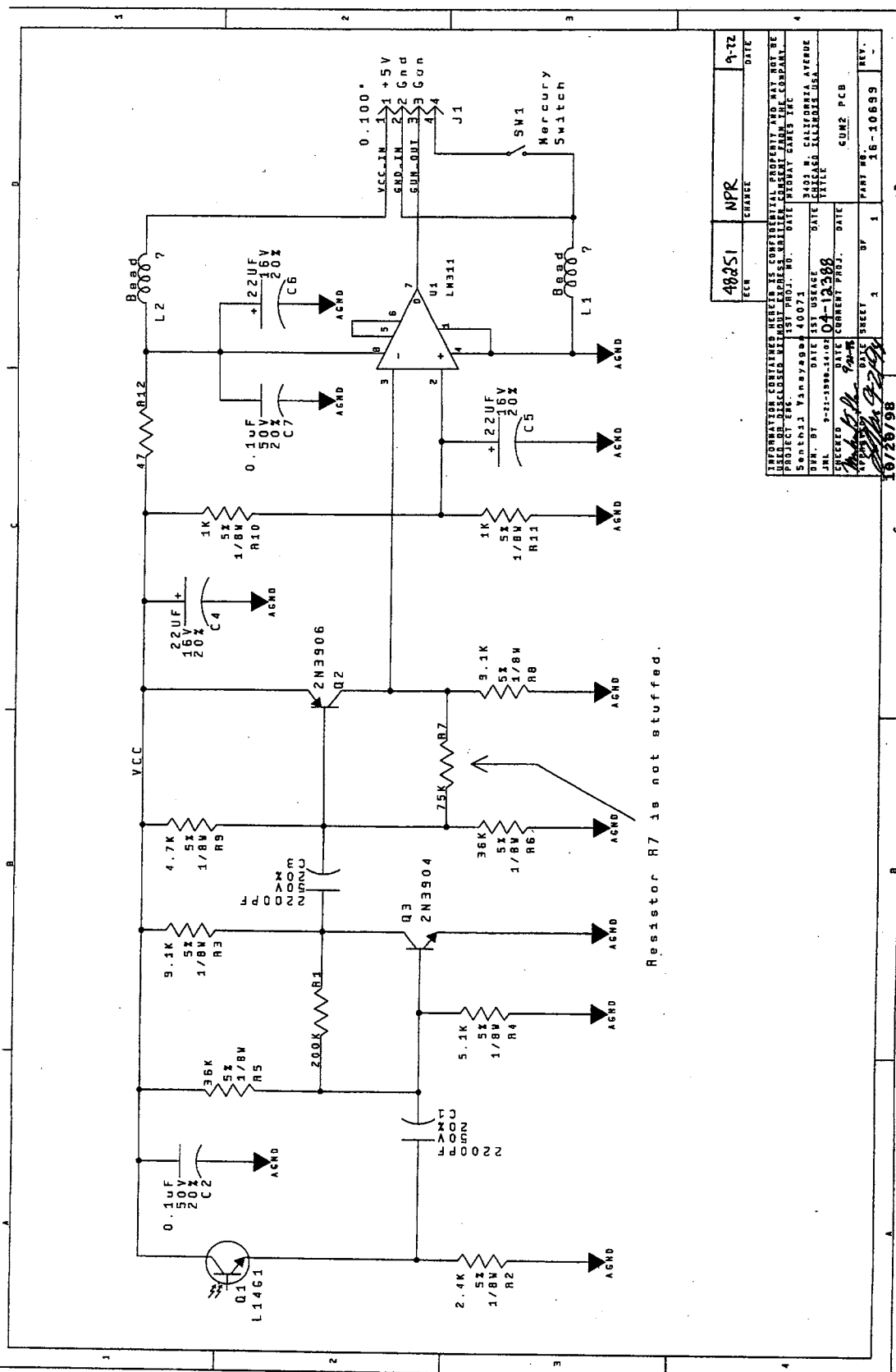

Resistor R7 is not stuffed.

48251		NPR		DATE	
ECN	CHANGE	DATE	DATE	REV.	REV.
				16-10699	1
<small>INFORMATION CONTAINED HEREIN IS UNCLASSIFIED EXCEPT WHERE SHOWN OTHERWISE. IT IS THE POLICY OF THE U.S. GOVERNMENT TO MAKE AVAILABLE TO THE PUBLIC INFORMATION THAT IS NOT WITHIN THE SCOPE OF EXECUTIVE ORDER 11652, WHICH RELATES TO INFORMATION THAT IS RELATIVE TO NATIONAL DEFENSE. DATE: WEDNESDAY, APRIL 14, 1989.</small>					
<small>PROJECT ENG. 3403 M. CALIFORNIA AVENUE, CHICAGO, ILLINOIS, USA.</small>					
<small>DATE 1ST USAGE: 04-13-88</small>					
<small>DATE CURRENT PROJ. DATE</small>					
<small>DATE SHEET 1 OF 1 PART NO. 16-10699 REV.</small>					
<small>10/26/98</small>					

Gun Printed Circuit Board Schematic

WAVENET/NSS CONNECTOR

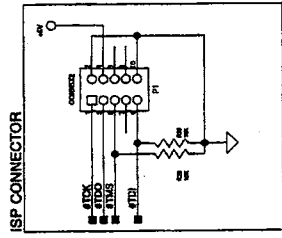
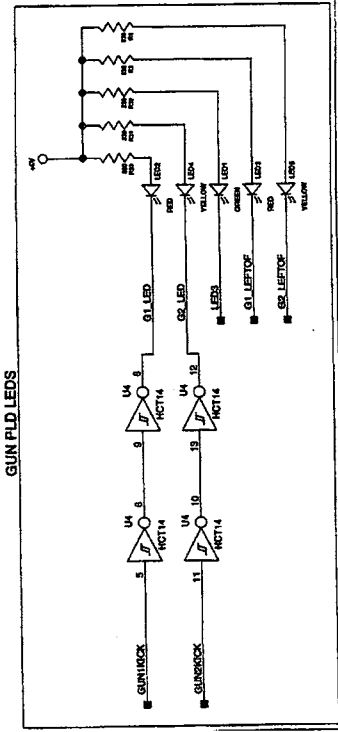
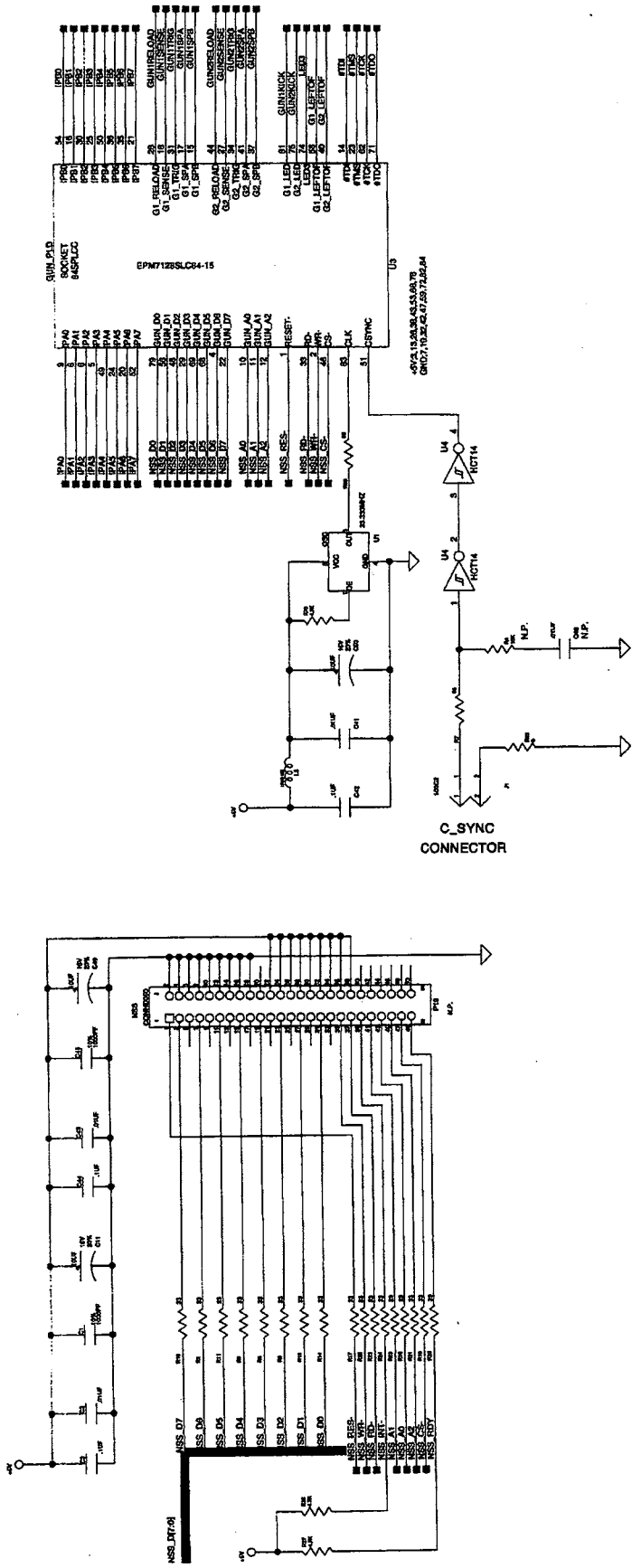

48250	CHANGE	DATE	09-22-98
INFORMATION CONTAINED HEREIN IS CONFIDENTIAL, PROPRIETARY AND MAY NOT BE DISCLOSED OR USED FOR ANY PURPOSES WITHOUT THE EXPRESS WRITTEN CONSENT OF LUCAS COMPANY.			
PROJECT NAME	TEST PRGM. INC. DATE		
DESIGNED BY	DATE	1ST USAGE DATE	04-11-80
DESIGNED BY	DATE	CURRENT PRGM. DATE	9-21-98
APP. DATE	DATE	SECRET	2 OF 3
PART NO.			16-10700

McWhorter Controls, Inc.
 8711 N. CALIFORNIA AVENUE
 SEATTLE, WA 98148
 206-735-1234
 FAX 206-735-1235

Gun Interface Printed Circuit Board Schematic (Sheet 1 of 2)

PORTS A&B INPUTS AND THE GUN INPUTS

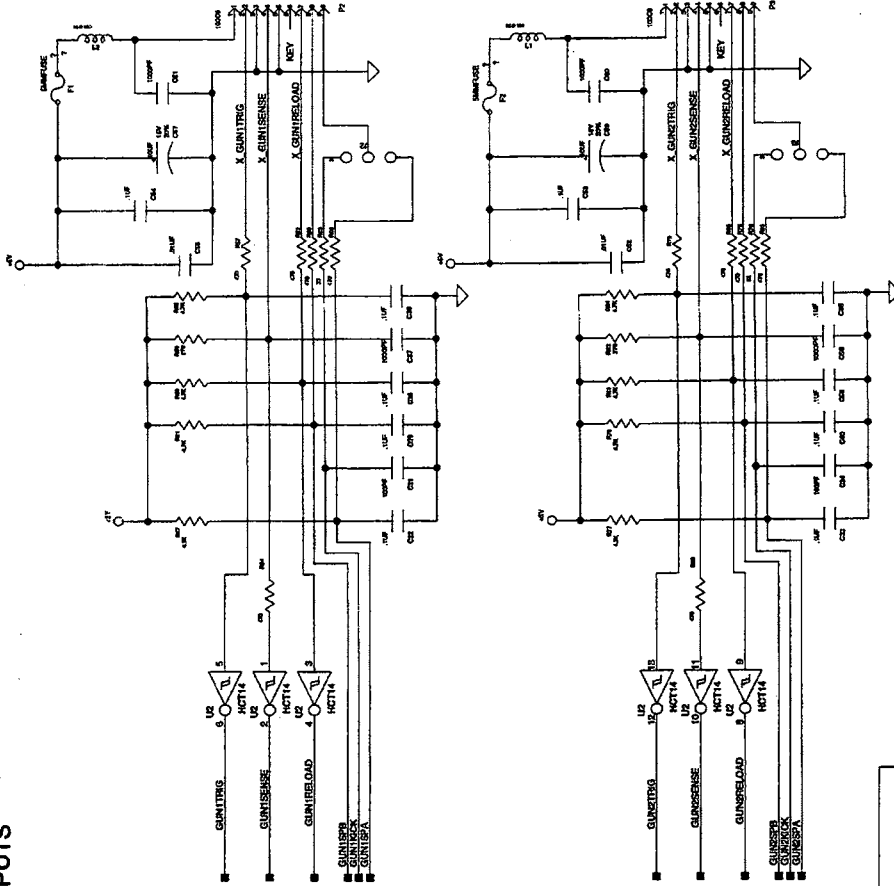

48250

REVISIONS	DATE	06-22-88
1	DATE	06-22-88
2	DATE	06-22-88
3	DATE	06-22-88
4	DATE	06-22-88
5	DATE	06-22-88
6	DATE	06-22-88
7	DATE	06-22-88
8	DATE	06-22-88
9	DATE	06-22-88
10	DATE	06-22-88
11	DATE	06-22-88
12	DATE	06-22-88
13	DATE	06-22-88
14	DATE	06-22-88
15	DATE	06-22-88
16	DATE	06-22-88
17	DATE	06-22-88
18	DATE	06-22-88
19	DATE	06-22-88
20	DATE	06-22-88
21	DATE	06-22-88
22	DATE	06-22-88
23	DATE	06-22-88
24	DATE	06-22-88
25	DATE	06-22-88
26	DATE	06-22-88
27	DATE	06-22-88
28	DATE	06-22-88
29	DATE	06-22-88
30	DATE	06-22-88
31	DATE	06-22-88
32	DATE	06-22-88
33	DATE	06-22-88
34	DATE	06-22-88
35	DATE	06-22-88
36	DATE	06-22-88
37	DATE	06-22-88
38	DATE	06-22-88
39	DATE	06-22-88
40	DATE	06-22-88
41	DATE	06-22-88
42	DATE	06-22-88
43	DATE	06-22-88
44	DATE	06-22-88
45	DATE	06-22-88
46	DATE	06-22-88
47	DATE	06-22-88
48	DATE	06-22-88
49	DATE	06-22-88
50	DATE	06-22-88
51	DATE	06-22-88
52	DATE	06-22-88
53	DATE	06-22-88
54	DATE	06-22-88
55	DATE	06-22-88
56	DATE	06-22-88
57	DATE	06-22-88
58	DATE	06-22-88
59	DATE	06-22-88
60	DATE	06-22-88
61	DATE	06-22-88
62	DATE	06-22-88
63	DATE	06-22-88
64	DATE	06-22-88
65	DATE	06-22-88
66	DATE	06-22-88
67	DATE	06-22-88
68	DATE	06-22-88
69	DATE	06-22-88
70	DATE	06-22-88
71	DATE	06-22-88
72	DATE	06-22-88
73	DATE	06-22-88
74	DATE	06-22-88
75	DATE	06-22-88
76	DATE	06-22-88
77	DATE	06-22-88
78	DATE	06-22-88
79	DATE	06-22-88
80	DATE	06-22-88
81	DATE	06-22-88
82	DATE	06-22-88
83	DATE	06-22-88
84	DATE	06-22-88
85	DATE	06-22-88
86	DATE	06-22-88
87	DATE	06-22-88
88	DATE	06-22-88
89	DATE	06-22-88
90	DATE	06-22-88
91	DATE	06-22-88
92	DATE	06-22-88
93	DATE	06-22-88
94	DATE	06-22-88
95	DATE	06-22-88
96	DATE	06-22-88
97	DATE	06-22-88
98	DATE	06-22-88
99	DATE	06-22-88
100	DATE	06-22-88

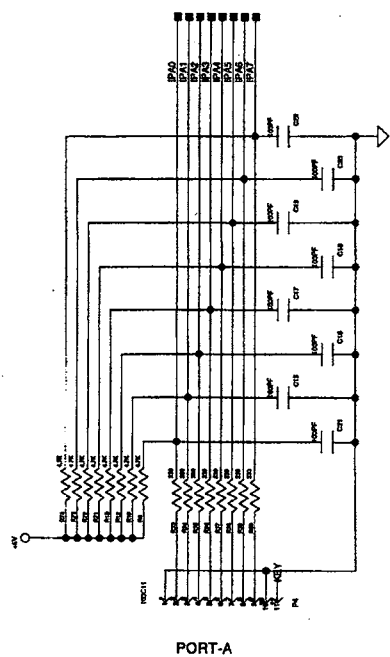

PORT-A

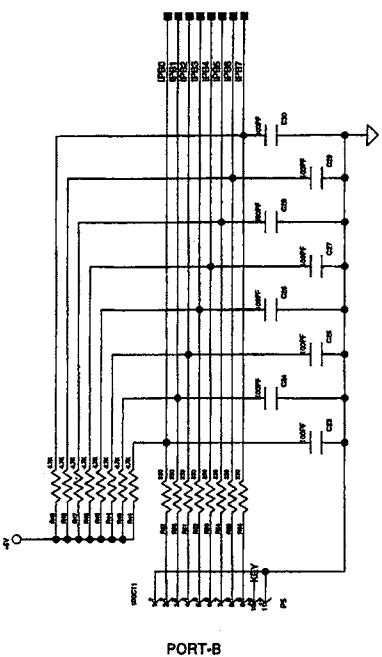

PORT-B

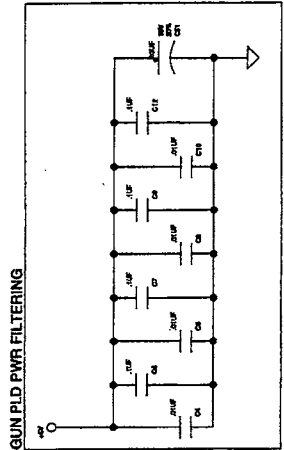

GUN PWR FILTERING

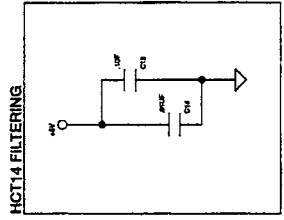

HCT14 FILTERING

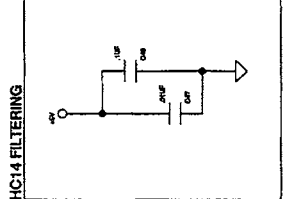

HC14 FILTERING

Gun Interface Printed Circuit Board Schematic (Sheet 2 of 2)

NOTES

Lined area for taking notes, consisting of 24 horizontal lines.

CARNEVIL™

SECTION FIVE

TROUBLESHOOTING



CAUTION: This game uses complex electronic components that are very SENSITIVE to static electricity. Observe the following precautions before handling game electronics. Failure to do so may void the warranty and could damage electronic assemblies.

1. Before servicing electronics, turn off A.C. power to the game. Wait for capacitors to discharge.
2. BEFORE touching or handling electronic assemblies, discharge static electricity on your body. To discharge this static, begin by connecting the line cord to a properly grounded outlet. Don't turn on the game! Next, touch the safety ground stud of the power supply chassis.
3. Store electronic assemblies in an anti-static area. Use anti-static bags to store or transport the game CPU Board assembly. Transport the Hard Disk Drive in its container.
4. DO NOT remove or connect any electronic assemblies when the cabinet power is ON. Doing so will damage electronic assemblies and void the warranty.
5. Replace ground wires, shields, safety covers, etc. after you complete maintenance or service. Install and firmly tighten all ground and mounting screws.

Game Startup Troubleshooting Table

SYMPTOM	REQUIRED ACTION
<p>GAME DOES NOT START</p> <ul style="list-style-type: none"> • Game appears completely non-functional. • No audio • No illumination • No video display 	<ol style="list-style-type: none"> 1. Check that Power Switch is ON on game power supply. 2. Turn OFF game power. Unplug A.C. line cord. Examine power supply fuse or circuit breaker. Power Line Voltage Switch must be set to agree with local A.C. line voltage. 3. Remove line cord from power supply. Test line cord, power plug, and I.E.C. connector for breaks or damage. Verify continuity of each wire in cord. Ensure that supply connector is good. Fully seat I.E.C. connector into mating receptacle of power supply. 4. Unlock and remove rear cabinet door. Swing door out until it rests on chains. Ensure that cabinet wiring harness connectors fully seat in corresponding power supply and CPU Board assembly. 5. Fully seat A.C. plug in power outlet. Verify presence of A.C. line voltage. Turn game power ON. If fuse opens again, check D.C. wiring harness and connectors.

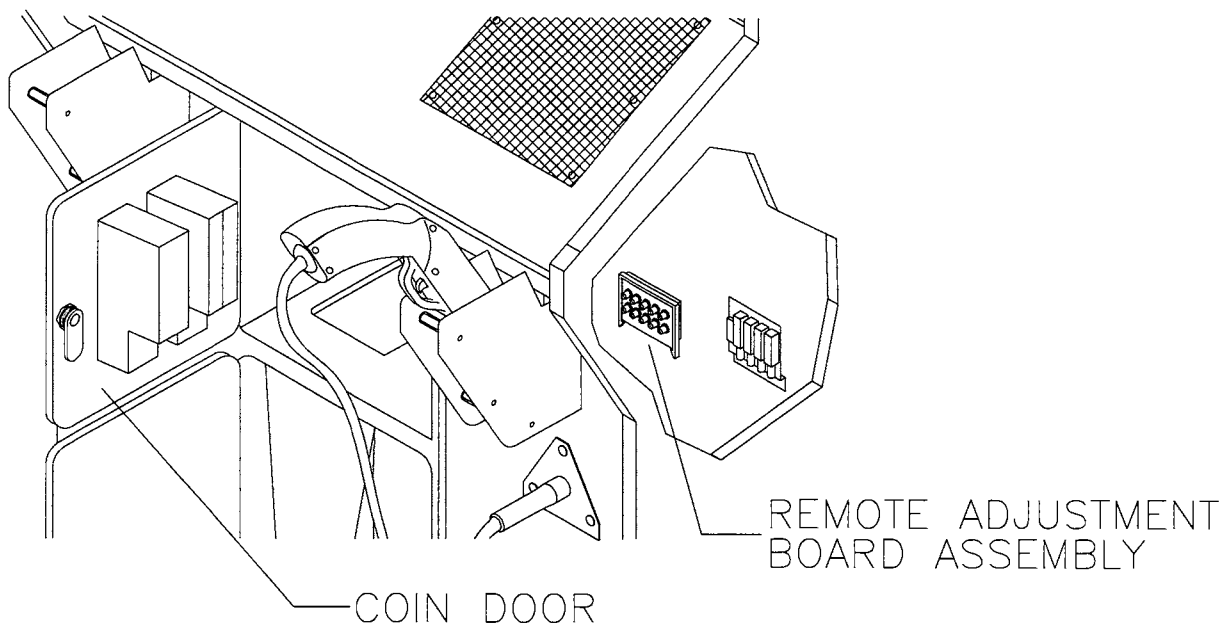

Location of Monitor Remote Adjustment Controls

Game Startup Troubleshooting Table, *continued*

SYMPTOM	REQUIRED ACTION
<ul style="list-style-type: none"> • Video game appears non-functional. • Currency acceptor price indicator is illuminated. 	<ol style="list-style-type: none"> 1. Unlock and open rear cabinet door. Inspect CPU Board assembly under low-light conditions. Light emitting diodes glow if processor circuits receive voltage. Fan should also be operating. These indications prove presence of some D.C. from power supply. Still, voltages or signals may not be normal. 2. Turn OFF game power. Inspect CPU Board assembly. Ensure that JAMMA Wire Harness connector is attached and fully seated onto mating board connector. Verify connection of monitor A.C. power. Check on wiring harness connectors in same way. 3. Verify that game CPU DIP Switches are set as intended. 4. Turn ON game power. Using 20 Volt D.C. setting on digital voltmeter, measure D.C. voltages present at power connector pins. Adjust +5V source if necessary. 5. Using 2-volt A.C. setting on digital voltmeter, measure same D.C. voltages as above. Any reading here indicates that supply voltages are unstable and may contain ripple or noise. 6. Verify that game runs and completes power-up self-test sequence without any errors. Note errors or failures during these tests (Game doesn't save error messages). 7. Enter game Menu System by pressing and holding TEST MODE switch inside coin door area. Select DIAGNOSTICS from Main menu. Once in DIAGNOSTICS menu, choose MONITOR SETUP.



CAUTION: Do not remove or install any connector while power is turned on. Doing so will damage the CPU Board or hard disk drive, and void the warranty.

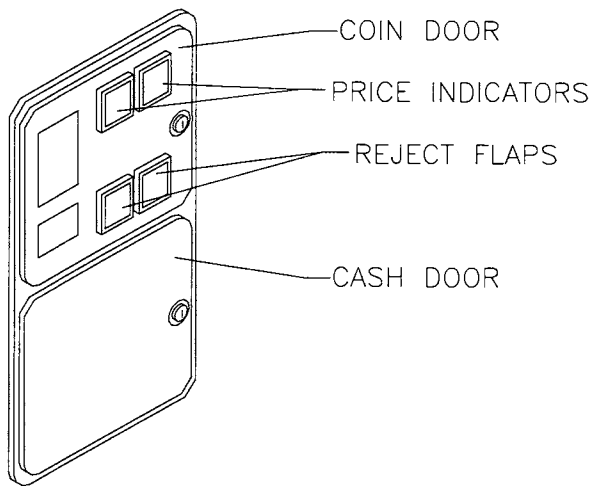

Front View of Coin Door

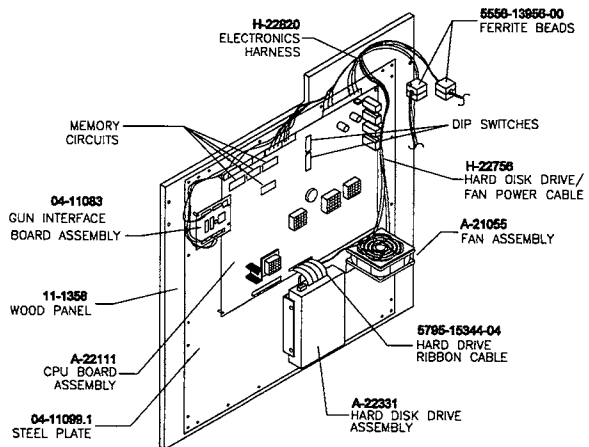

Interior View of Electronics

Game Startup Troubleshooting Table, *continued*

SYMPTOM	REQUIRED ACTION
<ul style="list-style-type: none"> • Game will not accept currency or tokens and cannot be started. • Audio and video are present. 	<ol style="list-style-type: none"> 1. Unlock and open cash door. Empty cash box. Inspect revenue for counterfeit currency. Check vault and remove any items that block path from mechanism. 2. Unlock and open coin door. Check each mechanism by hand to ensure proper mounting. Remove mechanism and clear currency path. Reinstall mechanism and latch it. 3. Verify that mechanism is level when doors close. Repair or replace coin door if it is bent or damaged. If necessary, adjust cabinet leg levelers to keep mechanisms vertical.
<ul style="list-style-type: none"> • Game accepts currency or tokens, but does not start. • Audio and video are present. 	<ol style="list-style-type: none"> 1. Unlock and open coin door. Check each currency acceptor by hand to ensure proper mounting. Verify that each of release latches is in closed and locked position. Test known good and bad coins to see if mechanism accepts and rejects currency correctly. 2. Ensure that no loose parts or wires are caught in hinges, latches, or switch contacts. 3. Inspect to see if external acceptor indicators (Pricing, Flashing Arrows, etc.) are illuminated. Check connectors and cables for wiring continuity from CPU Board connectors to acceptors. 4. Enter game Menu System by pressing and holding TEST MODE switch inside coin door. From DIAGNOSTICS menu, choose SWITCH TESTS. Use these tests to confirm operation of each switch used in game. 5. Check for continuity in each of suspect switch connections (Common to Normally Open or Common to Normally Closed). Replace faulty switches (bent levers, broken actuators, etc.). 6. Verify that each acceptor is operating properly by placing it in known good unit.

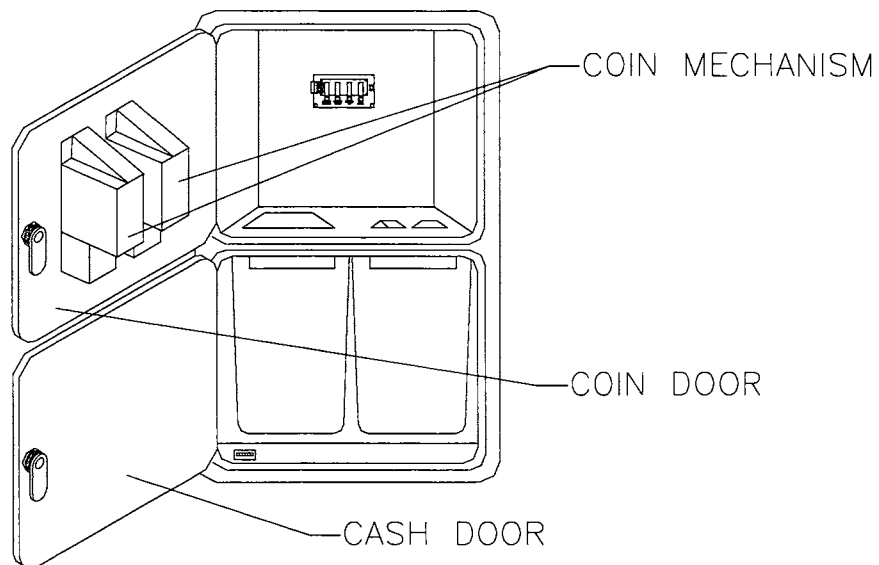

Interior View of Coin Door and Cash Door

Game Startup Troubleshooting Table, *continued*

SYMPTOM	REQUIRED ACTION
<ul style="list-style-type: none"> • Player controls are intermittent or completely non-functional. • Game starts normally. 	<ol style="list-style-type: none"> 1. Unlock and open coin door. Enter game Menu System by pressing and holding TEST MODE switch inside coin door. From DIAGNOSTICS menu, choose SWITCH TESTS. Use these tests to confirm operation of each switch used in game. 2. Unlock and open coin door. Ensure that no loose parts or wires are caught in hinges, latches, or switch contacts. Verify that harness connectors are attached and fully seated. 3. Check that cabinet wiring is correct for this game. Ensure that control switches connect properly to control input wires from P3, P16 and JAMMA connector. 4. Verify continuity in each of switch connections (Common to Normally Open or Common to Normally Closed). Ensure that control is operating properly by placing in known good unit. 5. Guns malfunction or don't work: See Shotgun Troubleshooting Table.
<p>Game accepts currency or tokens, but number of credits per coin or bill is incorrect.</p>	<ol style="list-style-type: none"> 1. Unlock and open coin door. Enter game Menu System by pressing and holding TEST MODE switch inside coin door. From DIAGNOSTICS menu, choose SWITCH TESTS. Use these tests to confirm operation of each switch used in game. 2. From ADJUSTMENTS menu, choose PRICING to verify units and credits are set correctly. 3. Check that cabinet wiring is correct for this game. Ensure that coin meter and coin switches connect properly to control input wires from JAMMA connector and or CPU wiring.

Shotgun Troubleshooting Table

SYMPTOM	REQUIRED ACTION
<ul style="list-style-type: none"> • Players complain that one or both guns fail to hit targets • Game starts normally 	<ol style="list-style-type: none"> 1. Turn off room lights to eliminate glare on monitor. Unlock and open coin door. Enter game Menu System by pressing and holding TEST MODE switch inside coin door. From DIAGNOSTICS menu, choose GUN TEST. Use Targeting subtest to confirm accuracy of each gun. Retest guns with lights on. 2. From UTILITIES menu, choose RECALIBRATE. Use GUN CALIBRATION screen to reset each gun's aim. Stand directly behind gun holder and extend cable to its full length to ensure greatest accuracy. 3. Inspect each gun for missing screws, loose or damaged parts, broken cables, etc. Examine gun barrel and lens for dirt or debris. <i>Do not apply cleaner directly into gun barrel.</i> 4. Unlock and open coin door. Ensure that no loose parts or wires are caught in hinge or switch contacts. Check gun cable ground connections. Verify that harness connectors are attached and fully seated. 5. Verify that each gun assembly operates properly by placing it in known good unit.
<ul style="list-style-type: none"> • Guns are intermittent or completely non-functional • Game starts normally. 	<ol style="list-style-type: none"> 1. Check gun fuses on Gun Interface Board inside main cabinet. Each gun has its own fuse. 2. Enter game Menu System by pressing and holding TEST MODE switch inside coin door. From ADDITIONAL ADJUSTMENTS menu, choose FLASH BRIGHTNESS. This feature may be set too low. Factory recommended setting is .50. Increase setting and retest shotguns. (NOTE: GAMMA setting on Gun Test performs same function as FLASH BRIGHTNESS.) 3. Remove screws from gun. Separate pieces at handle end first, using care not to dislodge parts. (Trigger is spring loaded.) Check gun board, switches and switch connectors. Clean lens to remove fingerprints and dust. Reinstall shields removed during disassembly. After you reassemble gun, verify that good connection exists between static shield and cable ground. 4. Verify that each gun assembly operates properly by placing it in known good unit. 5. If gun still doesn't work, gun circuit board may be bad. Troubleshoot or replace board and retest gun.

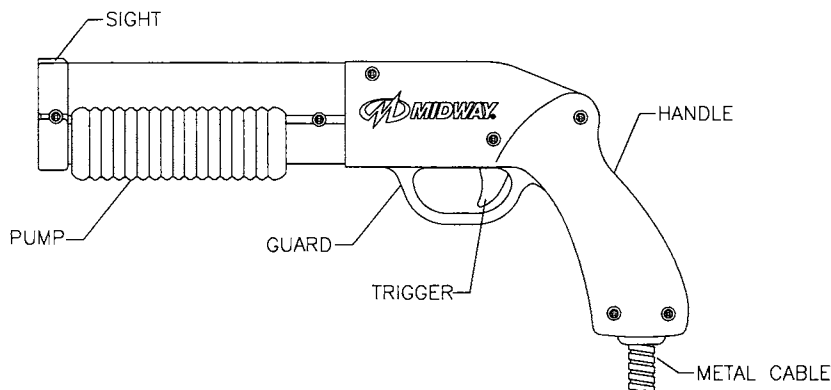

Shotgun Parts

Audio Troubleshooting Table



SYMPTOM	REQUIRED ACTION
<ul style="list-style-type: none"> • No audio • Video is present • Game appears to operate normally 	<ol style="list-style-type: none"> 1. Unlock and open coin door. Enter game Menu System by pressing and holding TEST MODE switch inside coin door. From Main Menu, choose VOLUME LEVEL. Verify that volume levels have not been set at zero. Change levels if necessary to make game audible. 2. From ADJUSTMENTS menu, choose ATTRACT SOUND to see if this feature is active (ON). 3. Follow on-screen instructions to return to first menu. Select DIAGNOSTICS from Main Menu. Once in DIAGNOSTICS menu, choose SOUND SUBSYSTEM. These tests confirm operation of each segment of sound system. 4. Turn off game power. Remove grilles and inspect speakers. Free speaker cones, terminals, mounting screws and magnets of loose parts or wires. 5. Verify correct cabinet wiring for this game. Ensure that speakers connect properly to audio output wires from JAMMA connector. Verify that each speaker has continuity. 6. Turn on game power. Using 20 volt D.C. setting on digital voltmeter, measure D.C. voltages present at power connector pins. Verify +5V, -5V and +12V sources. 7. Using 2 Volt A.C. setting on digital voltmeter, measure same D.C. voltages as above. Any reading here indicates that supply voltages are unstable and may contain ripple or noise. 8. Verify proper operation of game CPU Board assembly by placing it in known good game.

Audio Troubleshooting Table, *continued*

SYMPTOM	REQUIRED ACTION
<ul style="list-style-type: none">• Audio is distorted, muffled or missing frequencies.• Constant low hum may be present.	<ol style="list-style-type: none">1. Unlock and open coin door. Enter game Menu System by pressing and holding TEST MODE switch inside coin door. From Main Menu, choose DIAGNOSTICS from Main Menu. Once in DIAGNOSTICS menu, choose SOUND SUBSYSTEM. These tests confirm operation of each segment of sound system.2. Turn off game power. Remove grilles and check speakers. This game uses two coaxial speakers. Ensure that speakers are FULL RANGE (100 to 10,000 Hz response) and rated for at least 20 WATTS.3. Check for reversed wires at one speaker. Weak low frequencies and thin or hollow sound quality is symptom of incorrectly phased speakers. This condition may not be detected by SOUND SUBSYSTEM, but it will be audible during normal game operation.4. Check that cabinet wiring is correct for this game. Verify that cabinet wiring provides separate wires (not common return) for each speaker. Check connection of all cabinet ground wires.5. Using 2 Volt A.C. setting on digital voltmeter, measure voltages at speaker terminals. Any reading here indicates that supply voltages are unstable and may contain ripple or noise.6. Verify that speaker operates properly by placing in known good unit.

Video Troubleshooting Table

SYMPTOM	REQUIRED ACTION
<ul style="list-style-type: none"> • Monitor appears non-functional • Audio is present • Controls operate as expected 	<ol style="list-style-type: none"> 1. Unlock and open rear cabinet door. Verify connection of A.C. Power to Video Monitor. Inspect CRT neck under low light conditions. You'll see glow near CRT base if voltage appears across filament circuits. This indication proves that some monitor circuits receive power. Still, voltages or signals may not be normal. 2. Turn off game power. Verify that Video Signal and Remote Adjustment Board connectors seat properly on Video Monitor Board assembly. Check other monitor connectors in same way. 3. Examine A.C. line fuse on Video Monitor Board assembly. If fuse is faulty, replace it with an identical fuse of proper voltage and current rating. 4. Ensure that no loose parts or wires are caught on chassis or mounting brackets. 5. Check that brightness (intensity) and contrast have not been set to their minimum levels. 6. Verify that Video Monitor operates correctly by placing it in known good unit.

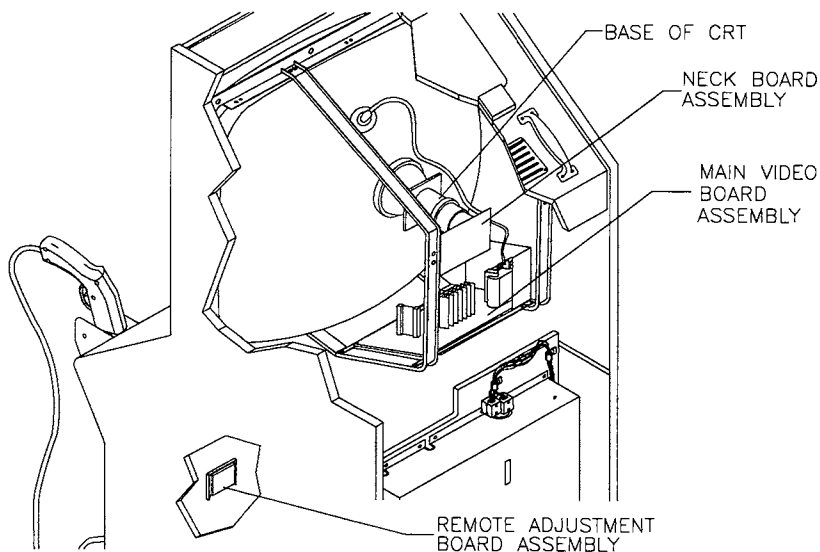

	<p>WARNING: In normal operation, the monitor does not require isolation from the A.C. line voltage. During bench servicing, etc., you may need to operate the monitor outside the cabinet. If you do, YOU MUST ISOLATE THE MONITOR FROM LINE VOLTAGE WITH AN ISOLATION TRANSFORMER.</p>
	<p>CAUTION: Do not operate monitor without the Remote Adjustment Board.</p>



Cutaway Rear View

Video Troubleshooting Table, *continued*

SYMPTOM	REQUIRED ACTION
<ul style="list-style-type: none"> • Game does not appear • No audio is present • Power-up self-test runs 	<ol style="list-style-type: none"> 1. Note and record any error messages that occur during self-test. Open coin door. Press and hold TEST MODE switch to enter menu system. Select DIAGNOSTICS from Main Menu. Once in DIAGNOSTICS menu, choose DISK TESTS. Use this set of tests to check operation of critical components. 2. Turn off game power. Unlock and open front door. Inspect CPU Board assembly. Ensure that JAMMA cable connector seats properly into mating edge connector on CPU Board. Check cable connectors for correct alignment and continuity. 3. Verify that ROM instruction set is correct for this game. Game set includes more than one ROM. Each ROM circuit is labeled with assembly number and software version. 4. Verify that CPU Board assembly is correct for this game. Each CPU Board is marked with manufacturer name, assembly number and hardware version. 5. Verify that hard disk drive assembly is correct for this game. Each hard disk drive unit is marked with manufacturer name, assembly number and program version. 6. Turn on game power. Using 20 Volt D.C. setting on digital voltmeter. Measure D.C. voltages present at power connector pins. Verify +5V source if it is adjustable. 7. Using 2 volt A.C. setting on digital voltmeter, measure same D.C. voltages as above. Any reading indicates that supply voltages are unstable and may contain ripple or noise. 8. Compare CPU Board jumper positions with CPU Jumper Status Chart (Section Four). Compare CPU Board light emitting diode states with CPU Indicator Chart (Section Three).

	<p>CAUTION: Do not remove or install any connector when power is turned on. Installation under power will damage the CPU Board or hard disk drive and void the warranty.</p>
	<p>NOTICE: Before adjusting the monitor, demagnetize the CRT with an industrial grade degaussing coil.</p>

Video Troubleshooting Table, *continued*

SYMPTOM	REQUIRED ACTION
<ul style="list-style-type: none"> • Monitor will not lock onto signal and provide stable picture • Colors are missing, etc. 	<ol style="list-style-type: none"> 1. Unlock and open coin door. Enter game Menu System by pressing and holding TEST MODE switch inside coin door. From DIAGNOSTICS menu, choose DIP-SWITCH TESTS. Verify that GRAPHICS MODE is correct. 2. Check connectors and cables for wiring continuity from CPU Board to video monitor. 3. Ensure that video monitor assembly is correct for this game. Use of video monitors with different resolution will result in horizontal tearing or complete loss of sync. 4. Verify that video monitor operates correctly by placing it in known good unit.
<ul style="list-style-type: none"> • Game operates normally • Video wavers or rolls, has dark bars, uneven colors, etc. 	<ol style="list-style-type: none"> 1. Check connectors and cables for wiring continuity from CPU Board to video monitor. 2. Ensure connection of all cabinet ground wires, especially at video monitor chassis. 3. Move cabinet far away from machines, appliances, or games, etc. During normal operation, some equipment emits very strong electrical or magnetic fields. 4. Verify that video monitor operates correctly by placing it in known good unit.

Software Update Troubleshooting Table

SYMPTOM	REQUIRED ACTION
<ul style="list-style-type: none"> • Update did not work • After update procedure, screen reports lower than latest version 	<ol style="list-style-type: none"> 1. You skipped steps or performed them out of sequence. This kit and its instructions resemble other game updates, but updates aren't identical. Return update components to kit, reinstall original parts in cabinet, and try process again. 2. You connected linked games to cabinet being updated. Network communication circuits may have prevented a full update. Turn off power to all connected cabinets. Then perform update on only one cabinet at a time. You need not disconnect linking cables. 3. An installation error may have damaged a device. Inspect for bent or broken pins. If you have another kit, try it. Your distributor can check your EPROMs.
<ul style="list-style-type: none"> • Game does not recover • Board indicators illuminate, but screen is completely blank 	<ol style="list-style-type: none"> 1. Boot Update version and hard disk drive don't match. Once you've updated disk drive, CPU instructions must be at correct version to make use of new data stored on disk. Be certain that boot ROM device resides in socket U32. 2. You may have installed devices in wrong sockets. Only use socket U33 for hard disk drive updates. During game play, socket U33 must be empty. After you install disk ROM and load its contents onto drive, remove it from game.

	<p>NOTICE: Someday, software updates for your game might become available. These upgrades may improve your game's performance or add new game features. Such upgrades tend to appear sometime after the factory first releases a game. Contact your distributor for information about updates.</p>
---	---

Miscellaneous Problem Troubleshooting Table

SYMPTOM	REQUIRED ACTION
<ul style="list-style-type: none"> • Marquee lamp is intermittent or non-functional • Game starts and plays normally. 	<ol style="list-style-type: none"> 1. Open front door and formed housing. Remove fluorescent tube from its sockets. If you find cracks or darkened ends, install new lamp. Clean tube. 2. Verify that lamp pins make good connection with socket contacts. 3. Measure fluorescent lamp assembly A.C. voltages. Check wiring and connector continuity from power supply connector to lamp assembly. 4. Check continuity of both fluorescent lamp filaments. Verify that lamp operates by placing it in known good unit.
<ul style="list-style-type: none"> • Game operates normally • Fan is noisy 	<ol style="list-style-type: none"> 1. Check bottom and rear of cabinet for blocked air flow. Move game away from sources of heat. 2. Turn off game power. Apply high power vacuum cleaner to vent holes to remove dust. 3. Unlock and open front door under monitor. connection and operation of all fans.
<ul style="list-style-type: none"> • Error Messages appear on screen • Game does not start and has no audio. 	<ol style="list-style-type: none"> 1. Check any assembly (RAM, ROM, Battery, etc.) identified in error messages. 2. Call your authorized distributor for help with unresolved screen messages.



WARNINGS & NOTICES

WARNING

USE OF NON-MIDWAY PARTS OR CIRCUIT MODIFICATIONS MAY CAUSE SERIOUS INJURY OR EQUIPMENT DAMAGE! USE ONLY MIDWAY AUTHORIZED PARTS.

- * For safety and reliability, substitute parts and modifications are not recommended.
- * Use only authorized components and parts. Failure to do so will void warranty and may result in incorrect and/or unsafe operation. Substitute parts or modifications may void EMC directive or FCC type acceptance.
- * This game is protected by Federal copyright, trademark and patent laws. Unauthorized modifications may be illegal under Federal law. This also applies to MIDWAY GAMES INC. and CARNEVIL logos, designs, publications and assemblies. Moreover, facsimiles of MIDWAY equipment (or any feature thereof) may be illegal under federal law, regardless of whether or not such facsimiles are manufactured with MIDWAY GAMES INC. components.

WARNING

Prevent shock hazard and assure proper game operation. Plug this game into a properly grounded outlet. Do not use a cheater plug to defeat the power cord's grounding pin. Do not cut off the ground pin.

WARNING

A very small portion of the population has a condition which may cause them to experience epileptic seizures or have momentary loss of consciousness when viewing certain kinds of flashing lights or patterns that are present in our daily environment. These persons may experience seizures while watching some kinds of television pictures or playing certain video games. People who have not had any previous seizures may nonetheless have an undetected epileptic condition.

If you or anyone in your family has experienced symptoms linked to an epileptic condition (e.g. seizures or loss of awareness), immediately consult your physician before using any video games.

We recommend that parents observe their children while they play video games. If you or your child experience the following symptoms: dizziness, altered vision, eye or muscle twitching, involuntary movements, loss of awareness, disorientation, or convulsions, DISCONTINUE USE IMMEDIATELY and consult your physician.

NOTE: This equipment has been tested and found to comply with the limits for a Class A digital device, pursuant to Part 15 of the FCC Rules. These limits are designed to provide reasonable protection against harmful interference when the equipment is operated in a commercial environment. This equipment generated, uses and can radiate radio frequency energy and if not installed and used in accordance with the instruction manual, may cause harmful interference to radio communications. Operation of this equipment in a residential area is likely to cause harmful interference in which case the user will be required to correct the interference at his own expense.

When MIDWAY GAMES INC. ships a game, it is in compliance with FCC regulations. Your label is proof of compliance. Legal repercussions to the owner or distributor may result if the label is missing or damaged. If your game does not contain an FCC compliance label, call MIDWAY GAMES INC. immediately.

NOTICE

No part of this publication may be reproduced by any mechanical, photographic, or electronic process, or in the form of a phonographic recording, nor may be transmitted, or otherwise copied for public or private use, without permission from the publisher.

MIDWAY® and CARNEVIL™ are trademarks of MIDWAY GAMES INC.

For Service: Call your Authorized MIDWAY GAMES INC. Distributor.

**MIDWAY GAMES INC.
3401 N. CALIFORNIA AVE.
CHICAGO, ILLINOIS 60618-5899
USA**