

namco® America Inc.



27" Video Game Cabinet

Operator's Manual

Important

**Read PRECAUTIONS and INSTALLATION
Sections before operating game**

FCC Notice

Note: This equipment has been tested and found to comply with the limits for a Class A digital device, pursuant to Part 15 of the FCC Rules. These limits are designed to provide reasonable protection against harmful interference when the equipment is operating in a commercial environment. This equipment uses, and can radiate radio frequency energy and, if not installed and used in accordance with the instruction manual, may cause harmful interference to radio communications. Operation of this equipment in a residential area is likely to cause harmful interference in which case the user will be required to correct the interference at his own expense.

Copyright 1998 NAMCO AMERICA INC. - All rights reserved

No part of this publication may be reproduced by any mechanical photographic, or electronic process, or in the form of a phonographic recording, nor may it be stored in a retrieval system, transmitted, or otherwise copied for public or private use, without permission from NAMCO AMERICA INC.

Table of Contents

1.0 SPECIFICATIONS1

2.0 INTRODUCTION2

2.1 Maximizing Earnings2

2.2 Game PCB2

3.0 PRECAUTIONS.....3

3.1 Installation3

3.2 Handling3

4.0 SET-UP AND TEST.....5

4.1 Test Mode5

4.2 Test Mode Procedure.....5

4.3 TEST Menu.....5

4.3.1 DISPLAY TEST.....6

4.3.1.1 Color Edit6

4.3.1.2 DIAGONAL Test Pattern7

4.3.1.3 COLOR BAR Test Pattern8

4.3.1.4 CONVERGENCE Test Pattern9

4.3.2 SWITCH TEST.....10

4.3.3 SOUND TEST11

4.3.4 JVS CABINET OPTIONS.....11

4.3.5 GAME OPTIONS12

4.3.6 COIN OPTIONS13

4.3.7 PLAY DATA.....14

4.3.8 DATA CLEAR.....14

4.3.9 EXIT & SAVE.....14

5.0 PCB CONNECTOR TABLES15

5.1 JAMMA Edge Connector15

5.2 Extended Edge Connector16

ILLUSTRATIONS, PARTS LISTS, & WIRING DIAGRAM17

1.0 SPECIFICATIONS

Power Supply:	200 Watt computer-grade switcher, +5 VDC and +12VDC outputs
Input Power	115-125VAC, 50/60 Hz, 4A (max)
Game PCB	Namco System 12 (EHRGEIZ)/Sony COH-700
Control Panel:	2-player configuration Each player: 8-way joystick and 4 move buttons
Harnesses:	56 pin JAMMA-type, key installed at pins H & 7 48 pin extension, key installed at pins A5 & B5
Monitor:	Horizontally mounted, Wells-Gardner 27 inch K7400 Scanning retrace: interlace Horizontal sync frequency: 15.75 kHz Vertical sync frequency: 60 Hz
Dimensions	34" W x 42" D x 75.3" H
Crated Dimensions:	40" W x 46" D x 80" H
Weight:	334 LBS
Shipping Weight:	364 LBS

EHRGEIZ CONTROL PANEL

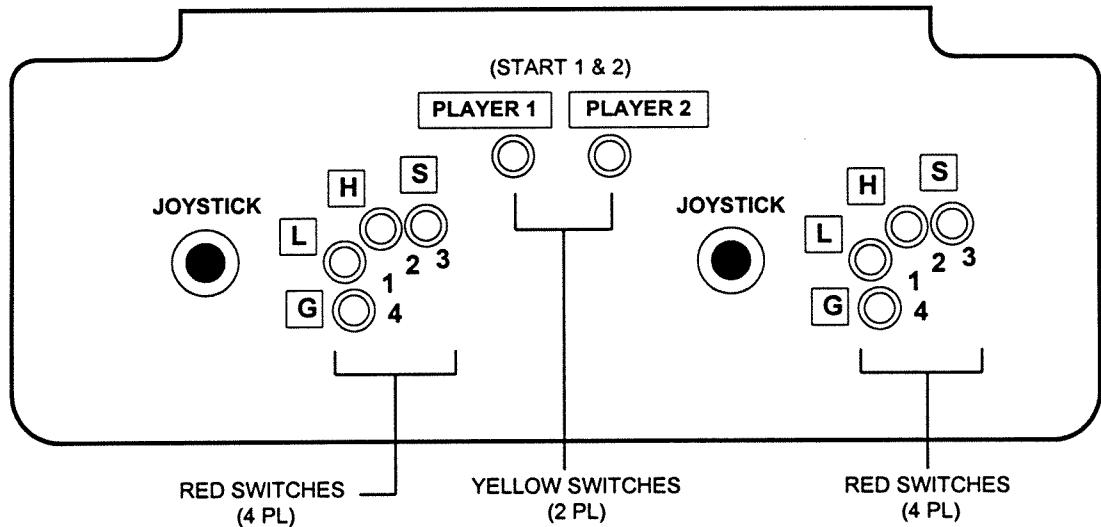

Note: Specifications are subject to change without prior notice. Modification and/or alteration of the Ehrgeiz game cabinet with parts not supplied by NAMCO may void the warranty.

2.0 INTRODUCTION

EHRGEIZ is the latest high performance, low cost, two-player, 3-D fighting game from Namco. Powered by the proven System 12 PCB, the game features the popular time release and test modes of the Tekken series, and new complex interactive backgrounds which are sure to keep them coming back for more!

2.2 Maximizing Earnings

To achieve optimum earnings it is recommended that you set the game to Namco's USA RECOMMENDED FACTORY SETTINGS. We believe that these settings are the most suitable for a wide variety of locations. These settings are shown in the Game Options and Coin Options test screens. However, as all locations are not alike, settings are easily adjustable via the TEST MODE menu options.

2.3 Game PCB

Test Switch 1	When the external service/test panel is used, this switch should be set to OFF. Test mode ON/OFF will be controlled by the external TEST switch. If PCB Test Switch 1 is ON, the game will be in Test mode.
Test Switch 2	Set to OFF. When ON, the screen is in Stop mode.
Volume control	Turn clockwise to increase audio volume. Used in combination with the external potentiometers, the PCB volume control should be adjusted fully CW.

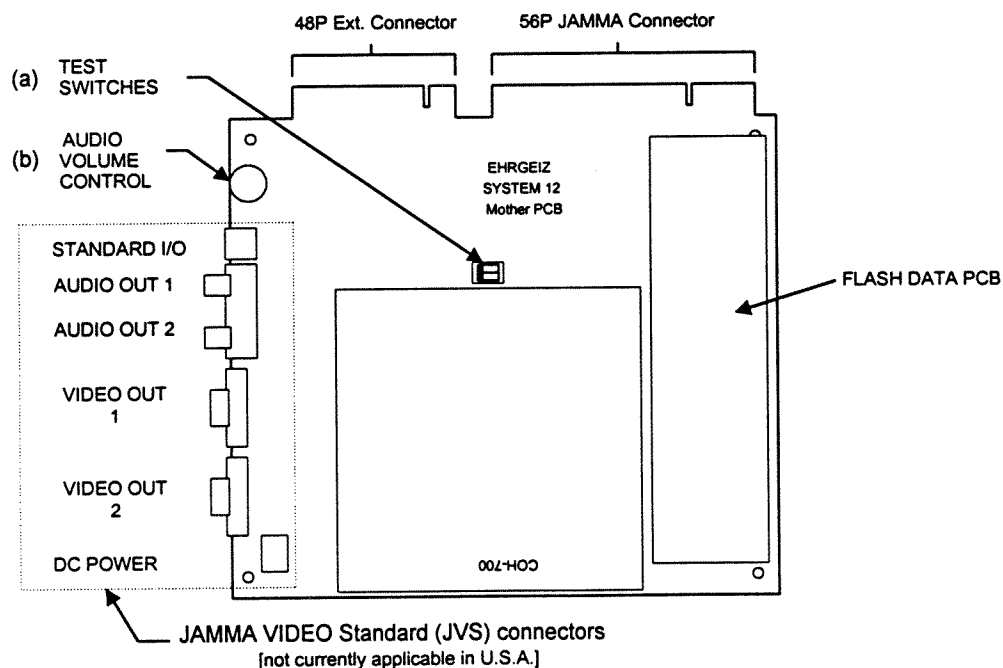

3.0 PRECAUTIONS

3.1 Installation

- 1.** This game is designed for indoor use only. The following conditions must be met:
- 2.** The game location must be free of direct exposure to sunlight, high humidity, dust, high heat or extreme cold. If installed in an unusually hot location, allow additional clearance between the rear of the game cabinet and any structure which would tend to restrict air circulation.
Do not install in an area such that the game would present an obstacle in case of an emergency (i.e., near fire equipment or emergency exits).
- 3.** The game must rest solidly on its leg levelers to prevent it from rocking or vibrating during game play.
- 4.** Before operating the game, make sure that the main AC power hookup includes a safety ground. This will ensure safe operation as well as compliance with the applicable FCC and UL requirements.

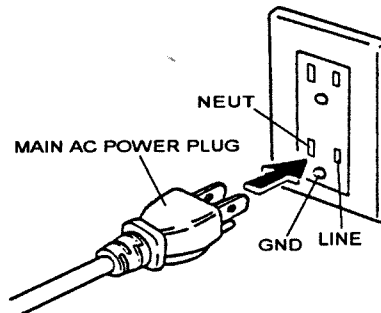

- 5.** Measure the AC line voltage [LINE to GND and LINE to NEUT] and verify that it is between 110 and 125VAC. NEUT to GND voltage should be less than 1VAC.

3.2 Handling

- 1.** Before replacing any parts, turn the AC power OFF and unplug the game.
- 2.** Do not attempt to repair the Printed Circuit Boards (PCBs) on-site. They contain sensitive integrated circuit chips that could be easily damaged, even by the small internal voltage of a multimeter. Always return the PCBs to your distributor for any repairs.

Operator's Manual

- 3.** The game monitor has areas of high voltage. Take care at all times to avoid electrical shock whenever inspecting or adjusting the game. Before servicing the monitor(s), **make sure the game is unplugged.**

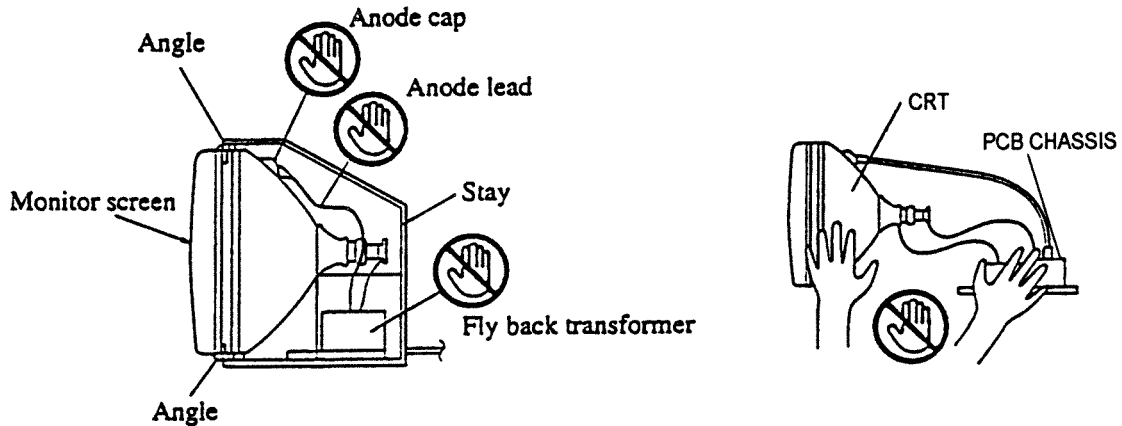

- 4.** Within the game cabinet ferrite clamps and shields have been included where needed to control electric field emissions. Removal or relocation of either the ferrites or shields will cause the FCC specification limits to be exceeded, and may cause faulty operation of nearby susceptible equipment. Also, re-routing or disconnection of grounds within the game system will result in excessive emissions and/or a safety hazard.
- 5.** Always exercise caution when moving the game to prevent damage to the leg levelers.
- 6.** After servicing the control panel, make sure to secure the latches.

4.0 SET-UP AND TEST

4.1 Test Mode

TEST mode allows the operator to test the game controls, set various game options, set coin options, and test the video monitor.

4.2 Test Mode Procedure

To enter TEST Mode, open the coin door and set the TEST switch to the ON Position.

Alt. Method: Flip Switch No. 1 on the System PCB to the ON position. Switch No. 2 should remain OFF at all times.

To adjust the setup options, follow these steps:

- 1.** Select the desired test screen (a) using the P1 joystick. The selected item is displayed in red.
- 2.** Display the selected screen by pressing P1-BUTTON 1.
- 3.** Within each screen, select and adjust each option using the P1 joystick and P1 buttons as indicated on the screen graphic.
- 4.** When exiting TEST Mode, always select EXIT & SAVE (b) before pressing P1-BUTTON 1 to end it. If EXIT & SAVE is not selected, TEST Mode will *not* be exited even if the TEST Switch is turned OFF.

4.3 TEST Menu

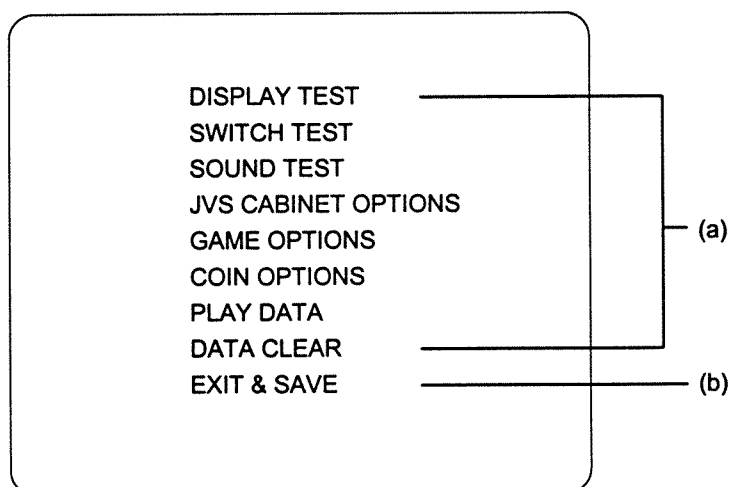

4.3.1 DISPLAY TEST

4.3.1.1 Color Edit

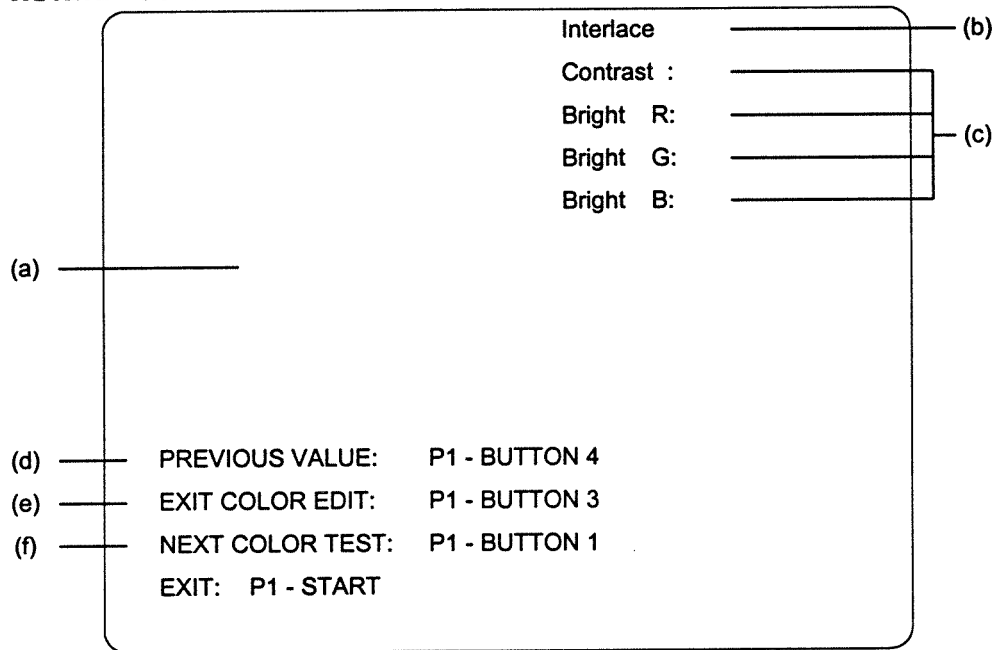

- a) Upon entering the DISPLAY TEST, the Color Edit screen data appears superimposed upon the DIAGONAL screen. Color Edit mode can be entered/exited from either of the 3 test pattern screens: DIAGONAL, COLOR BAR, or CONVERGENCE. Color Edit provides a means for adjusting the overall contrast and for balancing the brightness of the R, G, B signals. To select an item to be changed, move the P1 joystick up/down; to change the item setting, move the joystick right/left.
- b) Interlace or non-interlace scanning can be selected depending on the type of monitor used. Interlace will be suitable for the majority of game monitors. If excessive jitter is present, switch the scanning mode.
- c) Adjust contrast and brightness levels in accordance with preferences or standards. Before proceeding, it is best to verify that the monitor itself is in proper adjustment and that its screen has been degaussed.

Item	Range	Default
Contrast	00 - FF	A0
Bright R	00 - FF	18
Bright G	00 - FF	18
Bright B	00 - FF	18

- d) Press P1-BUTTON 4 to negate any changes.
- e) To remove the Color Edit data from the test pattern, press P1 - BUTTON 3.
- f) To proceed to the next test pattern, press P1 - BUTTON 1.

4.3.1.2 DIAGONAL Test Pattern

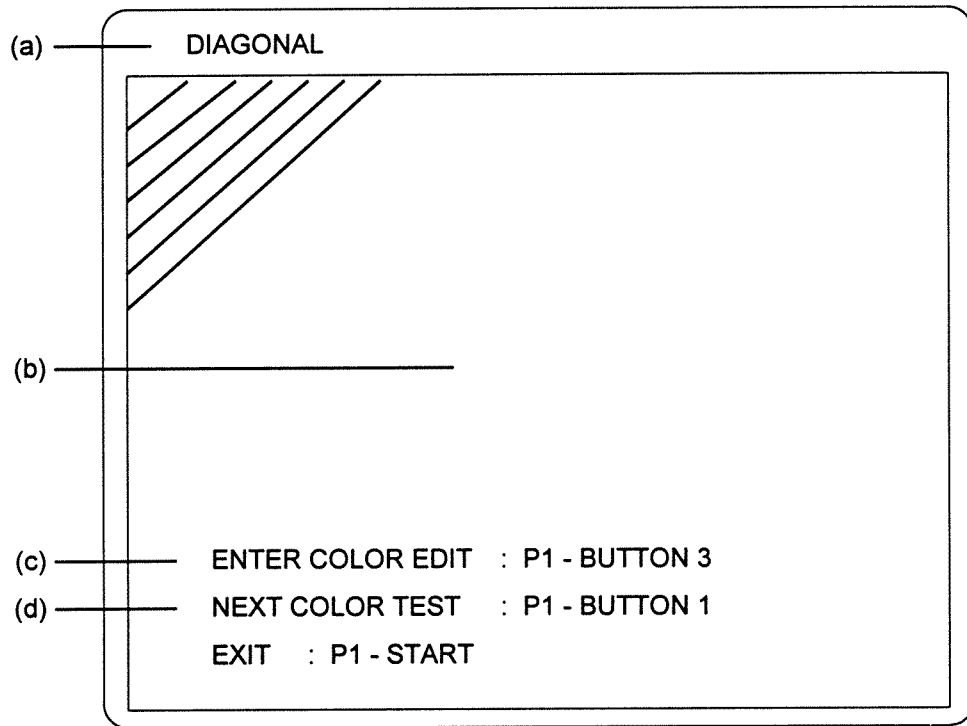

- a) The DIAGONAL test pattern is used to check the monitor in interlace scanning mode. (Reference Color Edit description).
- b) The default display consists of white diagonal lines on a black background. Press the P1-BUTTON 2 to sequence through additional display colors (blue, red, violet, green, light blue, yellow, black on white, and back to white). If display jitter is present, then switch interlace/non-interlace modes in Color Edit.
- c) The Color Edit adjustment screen can be called up by pressing P1-BUTTON 3.
- d) Press P1-BUTTON 1 to switch to the COLOR BAR test pattern.

4.3.1.3 COLOR BAR Test Pattern

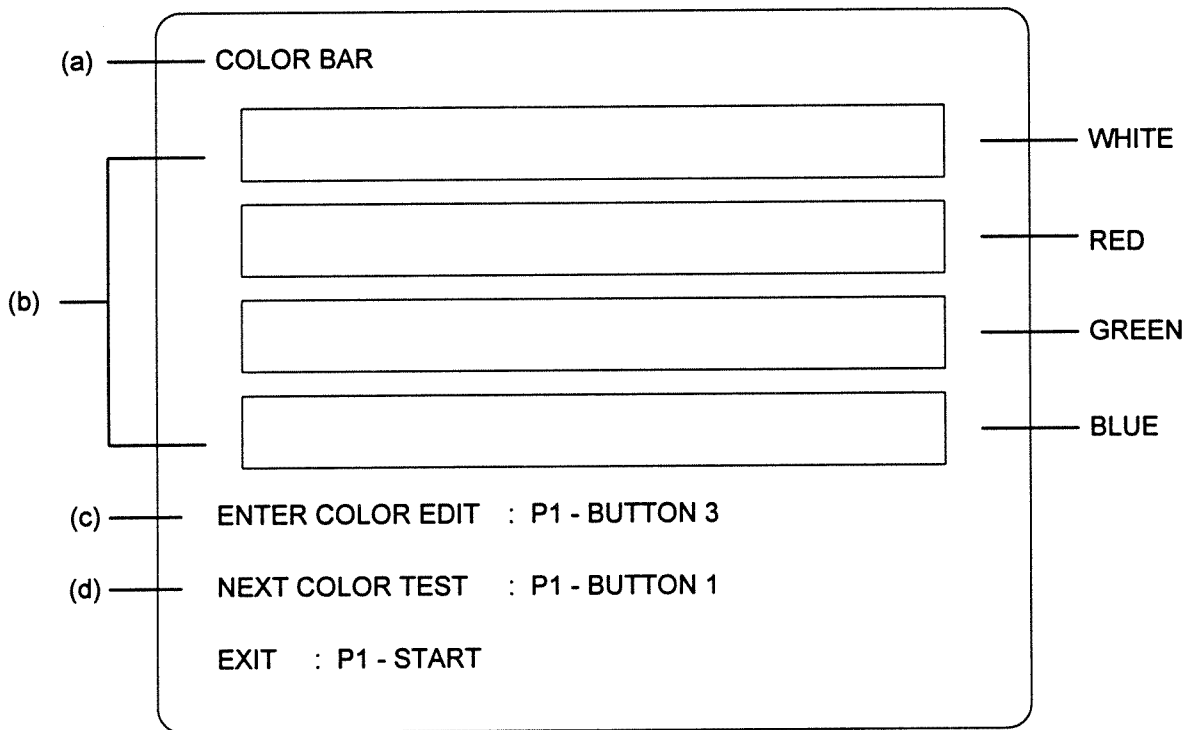

- a) The Color Bar test pattern can be used to check brightness, contrast and discrimination of the main colors.
- b) The default color bars are displayed in 32 brightness gradations. By pressing P1-BUTTON 2, colors bars of 16, 8, 4, and 2 gradations can be displayed.
- c) The Color Edit adjustment screen can be called up by pressing P1-BUTTON 3.
- d) Press P1-BUTTON 1 to switch to the CONVERGENCE test pattern.

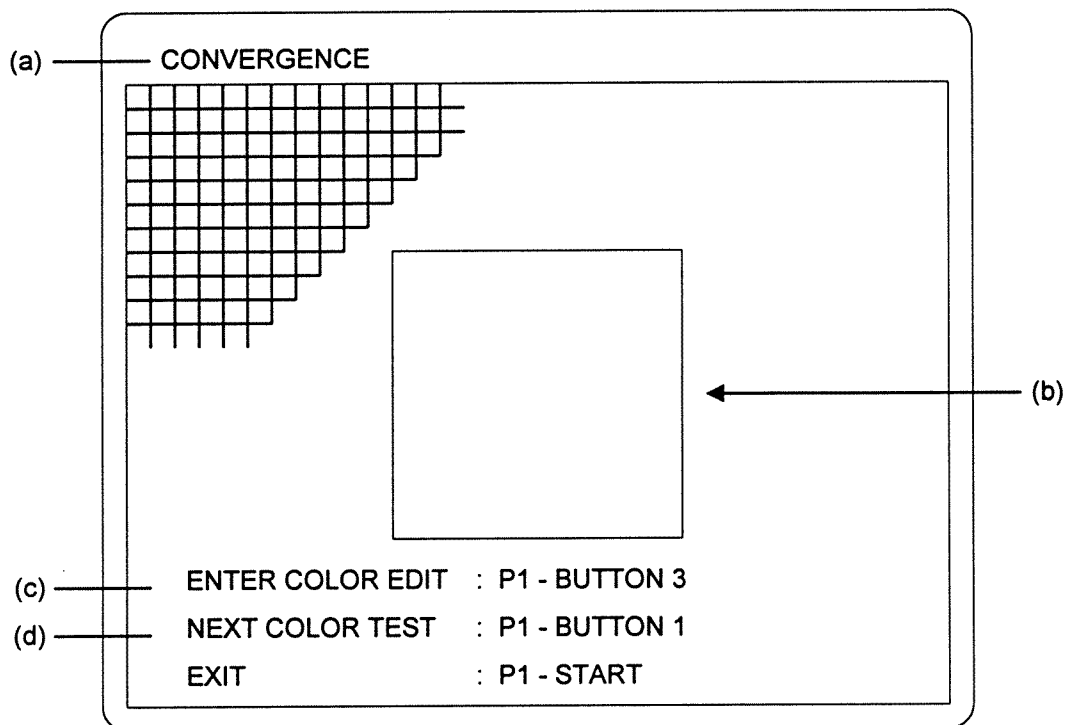
4.3.1.4 CONVERGENCE Test Pattern

- a) The CONVERGENCE test or “cross hatch” pattern can be used to verify and adjust the display size and position, and to check the distortion.
- b) The default display and “window” is white on a black background. If there is “bleeding” of R, G, B colors around the white grid lines, then monitor convergence adjustments can be made such that all three colors are coincident. (Refer to monitor service manual). Press the P1-BUTTON 2 to sequence through additional display colors (blue, red, violet, green, light blue, yellow, black on white, and back to white).
- c) Color Edit can be called up by pressing P1-BUTTON 3.
- d) Press P1-BUTTON 1 to switch to the DIAGONAL test pattern, or, press P1 - START to exit to the main test menu.

4.3.2 SWITCH TEST

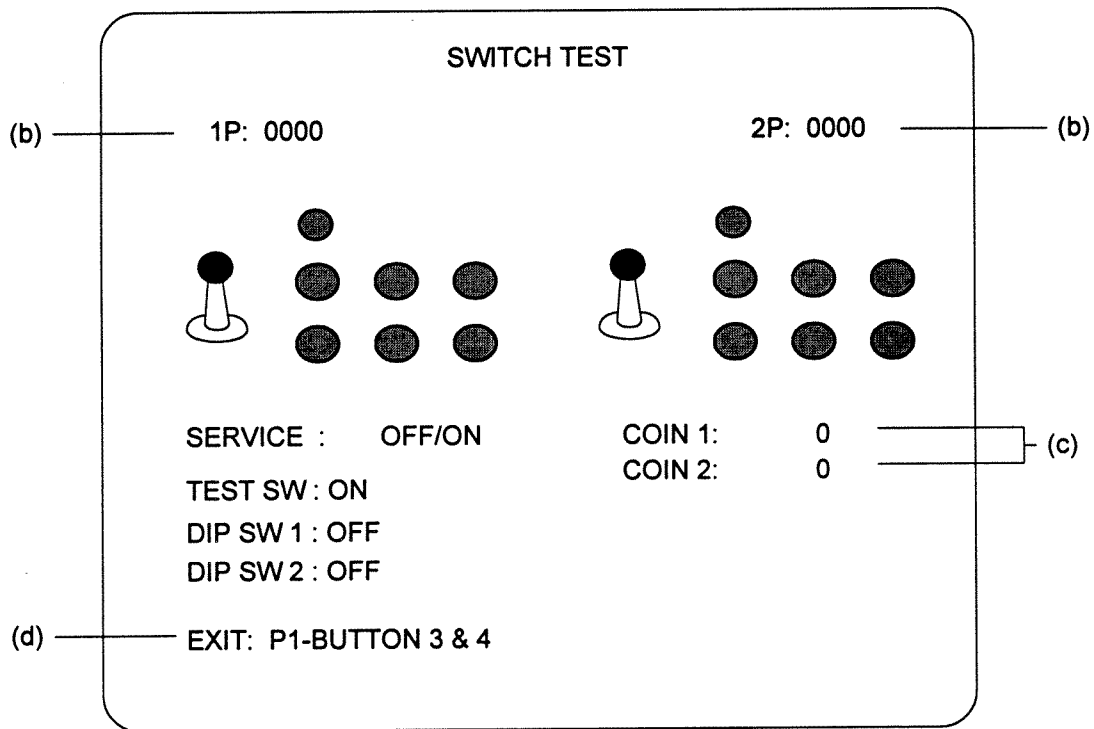

Notes:

- a) Active switches are highlighted in red.
- b) Switch format for both 1P and 2P is: P : n1 n2 n3 n4.

n1	→	0 = default, 1 = Joystick down, 2 = Joystick up, 8 = P-Start
n2	→	0 = default, 1 = SW 2, 2 = SW 1, 4 = Joystick (R), 8 = Joystick (L)
n3	→	0 = default, 4 = SW 4, 8 = SW 3
n4	→	0 = default

- c) Coin switch value increments 1 for each coin. Range: 0 to 999.
- d) Exit to the main test menu by pressing P1-BUTTONS 3 and 4 simultaneously.

4.3.3 SOUND TEST

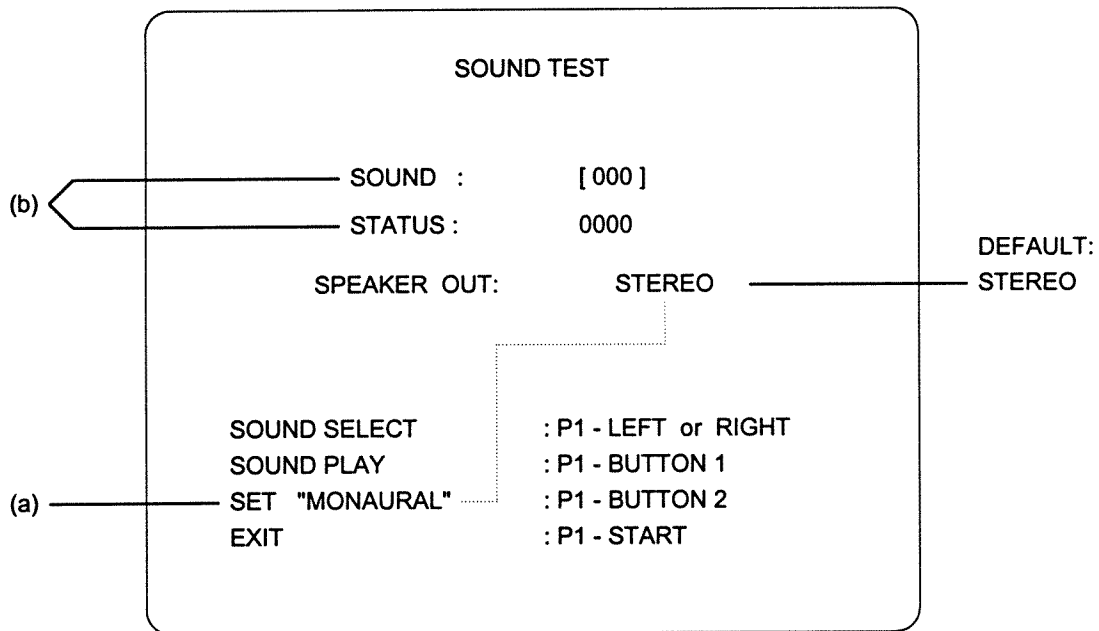

Notes:

- a) Press P1-BUTTON 2 to toggle between mono and stereo modes.
- b) Use the P1 Joystick (right) to increment the SOUND count. Use the Joystick (left) to decrement the count. Press P1-BUTTON 1 to test the item. While the test is active, STATUS 800X is displayed, where X is the SONG count.
- c) SONG 001 is the stereo output check.
- d) To adjust the audio volume, use either the volume control dial on the game PCB, or the external volume control potentiometers.

4.3.4 JVS CABINET OPTIONS

This item cannot be selected if the cabinet is wired as described using the JAMMA connectors.

4.3.5 GAME OPTIONS

GAME OPTIONS
<DEFAULTS IN GREEN>

DIFFICULTY LEVEL : MEDIUM _____ (a)

FIGHT COUNT <1P GAME> : 2 _____ (b)

FIGHT COUNT <VS GAME> : 2 _____ (c)

LIFE BAR <1P GAME> : -1 _____ (d)

LIFE BAR <VS GAME> : +1 _____ (e)

SET TIME : 45 SEC. _____ (f)

STAGE SELECT : YES _____ (g)

MUSIC IN ATTRACT : YES _____ (h)

EVENT MODE : NO _____ (i)

HIT COLOR : RED _____ (j)

SELECT TIME : 20 SEC. _____ (k)

SELECT : P1 - LEFT or RIGHT
EXIT : P1 - START

Values shown above are recommended settings.

- (a) DIFFICULTY LEVEL is the overall difficulty level of the game.
Range: EASY, MEDIUM, HARD, VERY HARD, ULTRA HARD
- (b) FIGHT COUNT <1P GAME> is the number of rounds required for victory in the 1P game.
Range: 1-5
- (c) FIGHT COUNT <VS GAME> is the number of rounds required for victory in the VS game.
Range: 1-5
- (d) LIFE BAR <1P GAME> is the life gauge during the 1P game.
Range: -2, -1, NORMAL, +1, +2
- (e) LIFE BAR <VS GAME> is the life gauge during the VS game.
Range: -2, -1, NORMAL, +1, +2
- (f) SET TIME is the time of play allowed per round.
Range: 20, 30, 45, 60, 99 Sec.
- (g) STAGE SELECT allows players the option of selecting the stage in which they wish to fight.
Range: YES, NO
- (h) MUSIC IN ATTRACT allows the sound to be turned on or off during attract mode.
Range: ON, OFF
- (i) EVENT MODE controls what happens at the end of game play.
Range: YES (game is over for both players), NO (if 1P, the winner continues)
- (j) HIT COLOR controls the color emitted during a hit.
Range: RED, GREEN
- (k) SELECT TIME is the time allowed to pick a character.
Range: 10, 15, 20, 30 Sec.

4.3.6 COIN OPTIONS

COIN OPTIONS <DEFAULTS IN GREEN>	
START COST : 2 COIN TO START	(a)
CONTINUE COST : 2 COIN TO CONTINUE	(b)
COIN CHUTE 1 MECHANICAL VALUE : 1 COIN COUNT AS 1 COIN	(c)
COIN CHUTE 2 MECHANICAL VALUE : 1 COIN COUNT AS 1 COIN	(d)
CREDIT MODE : COMMON	(e)
COIN COUNTER : 1 COUNTER	(f)
FREE PLAY : NO	(g)
SELECT : P1 - LEFT or RIGHT EXIT : P1 - START	

- (a) START COST range is 1-9 COINS. Default: 1.
- (b) CONTINUE COST range is 1-9 COINS, and must be less than or equal to (a). Default: 1.
- (c) & (d) COIN CHUTE 1 & 2 MECHANICAL VALUE is the value of each pulse from either coin switch 1 or 2, respectively. Range: 1 COIN COUNT AS (1-9) COIN. Default:1.
- (e) CREDIT MODE can be either COMMON or EACH ONE, depending on the wiring of the coin switches. If the switches are wired in parallel, select COMMON. If Player 1 and Player 2 are to be credited separately, select EACH ONE.
- (f) COIN COUNTER can be adjusted for either parallel coin switches (1 COUNTER), or for a Player 1 and Player 2 configuration (2 COUNTER).
- (g) FREE PLAY is either YES or NO. If YES is selected, all COIN OPTION changes are locked-out.

4.3.7 PLAY DATA

This mode provides data on play time in each mode, coin totals, character selection percentages, and VS game win/loss.

To select the display screen, press P1 - BUTTON 1.

To return to the main test menu, press the P1 - START switch.

4.3.8 DATA CLEAR

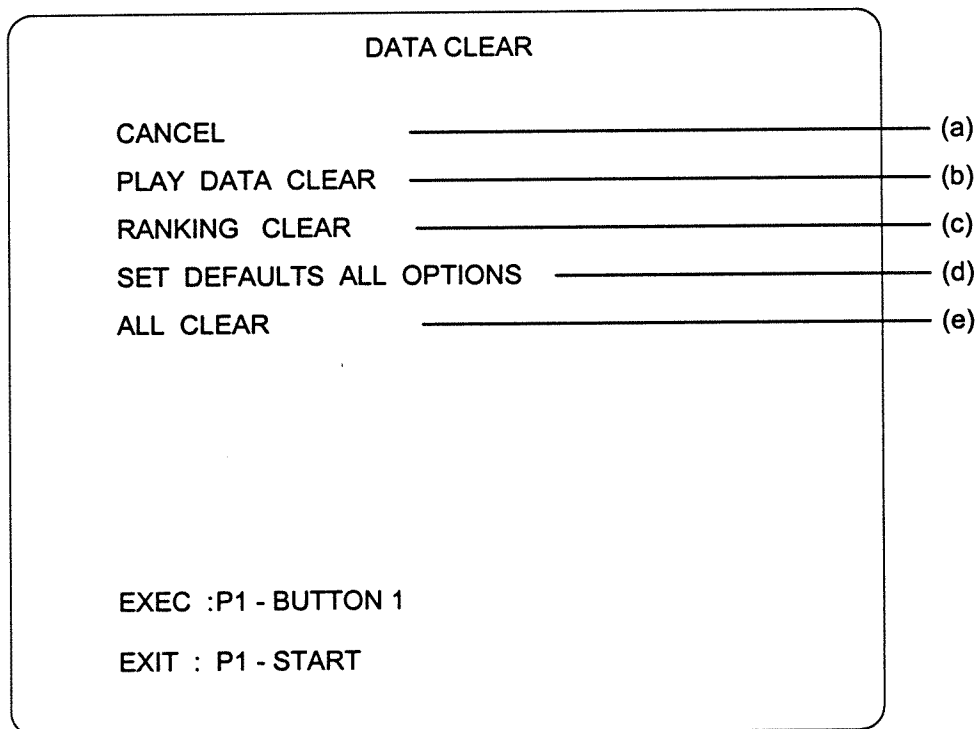

- a) CANCEL returns to the main test menu screen.
- b) PLAY DATA CLEAR effects the play data only.
- c) RANKING CLEAR initializes the ranking data to the factory default values.
- d) SET DEFAULTS ALL OPTIONS initializes all game options to their default values.
- e) ALL CLEAR performs both functions (b) and (c).

4.3.9 EXIT & SAVE

This mode allows a return to the game screen following completion of option adjustments.

EXIT & SAVE must be selected for changes to register.

Note: turn off the TEST switch following return to the game screen.

5.0 PCB CONNECTOR TABLES

5.1 JAMMA Edge Connector

(56 Pin 3.96 mm pitch)

Solder side	Terminal	No.	Parts side
GND	A	1	GND
GND	B	2	GND
+5V	C	3	+5 V
+5 V	D	4	+5 V
	E	5	
+12 V	F	6	+12 V
Insertion error preventing	H	7	Insertion error preventing
Coin counter 2	J	8	Coin counter 1
	K	9	
Speaker (-)	L	10	Speaker(+)
Audio GND	M	11	Audio (+)
Video GREEN	N	12	Video RED
Video SYNC	P	13	Video BLUE
Service Switch	R	14	Video GND
	S	15	Test switch
Coin switch 2	T	16	Coin switch 1
2P START switch	U	17	1P START switch
2P lever UP	V	18	1P lever UP
2P lever DOWN	W	19	1P lever DOWN
2P lever LEFT	X	20	1P lever LEFT
2P lever RIGHT	Y	21	1P lever RIGHT
2P BUTTON 1 (Low)	Z	22	1P BUTTON 1 (Low)
2P BUTTON 2 (High)	a	23	1P BUTTON 2 (High)
2P BUTTON 3 (Special)	b	24	1P BUTTON 3 (Special)
	c	25	
	d	26	
GND	e	27	GND
GND	f	28	GND

Notes:

- Do not connect leads to blank pins.
- The coin counter(s) operate on +12 volts
- Connect the switches to N.O. terminals and the GND to the COM terminal
- The +5V 5A and +12 V 2A supplies must be within +5% and -1% of nominal voltage.

5.2 Extended Edge Connector

(48 Pin 2.54 mm pitch 225D-10024C2-2312 or equivalent)

Solder side	Terminal No.		Parts side
Speaker R (-)	A1	B1	Speaker R (+)
	A2	B2	
	A3	B3	
	A4	B4	
key	A5	B5	Insertion error preventing key
	A6	B6	
	A7	B7	
2P BUTTON 4 (Guard)	A8	B8	2P BUTTON 5
+5V	A9	B9	GND
+5V	A10	B10	GND
	A11	B11	
	A12	B12	
	A13	B13	2P BUTTON 6
	A14	B14	
	A15	B15	
	A16	B16	
+5V	A17	B17	GND
+5V	A18	B18	GND
1P BUTTON 6	A19	B19	1P BUTTON 5
1P BUTTON 4 (Guard)	A20	B20	
	A21	B21	
	A22	B22	
+5V	A23	B23	GND
+5V	A24	B24	GND

Notes:

- Do not connect leads to blank pins.
- For Stereo and Mono setting select the speaker output in the SOUND TEST screen in test mode.
- Monophonic cabinets output only left channel sound when the stereo sound setting is selected.

Speaker connections

- Connect the (L) speaker to the speaker output of 56 Pin JAMMA edge connector.
- Connect the Right speaker to the speaker output of the 48 Pin edge connector.

ILLUSTRATIONS, PARTS LISTS, & WIRING DIAGRAM

ASSY, OVERALL, EZ01-07474-00

#	PART NO.	DESCRIPTION	QTY	NOTES
1	VG63-07479-00	Cabinet, System 12, 27 inch	1	
2	VG63-04468-01	Door, Rear	1	
3	VG63-04468-02	Electronic Tray, Wood	1	
4	MC26-03004-00	Lock , Door	1	
5		Leveler, Leg, 1/2-13 x 1-3/4, SZ	4	
6	VG10-06894-00	Plate, Leg Leveler	4	
7	VG85-06880-00	Monitor, Color, 27", Wells Gardner, K7400	1	
8	VG99-07469-00	Glass Tempered - Monitor	1	
9	VG99-07470-00	Glass Tempered - Marquee	1	
10	TK95-03163-00	Acrylic, Instruction Panel	1	
11	VG20-02860-16	Bolt, Hex HD, 1/4-20 x 1, SZ	4	
12	VG20-02864-07	Washer, Flat, 1/4", SZ	4	
13	RL90-02622-02	Bezel, Monitor, Blk Formed Plastic	1	
14	VG10-07471-00	Bracket, Bezel Restraint	2	
15	TK10-03157-00	Grill, Speaker Corner	2	
16	VG20-02901-12	Screw, Pan HD, #10-24 X 3/4, BO	10	
17	VG20-02865-05	Washer, Flat, #10, BO	10	
18	TK10-03159-00	Bracket, Speaker (B)	2	
19	VG54-03331-00	Speaker, 8 ohm, 20 watt, 4" , 4060	2	
20	TK97-03437-00	Baffle, Spkr, Duvetyne Cloth, 8-1/2 x 8-1/2, Blk	2	
21	VG57-00058-00	Fixture, Fluorescent, 18 inch, UL	1	
22	VG57-02992-00	Lamp, Fluorescent, 18 inch, UL	1	
23	GT57-02219-00	Fluorescent, Light Lock, Set	2	
24	GT95-02117-00	Grommet, 7/8 ID, dia hole	1	
25	VG44-02644-08	Label, Lamp Replacement (Fluor. 115V/15W)	1	
26	T210-04378-00	Lanyard, Control Panel Restraint	1	
27	VG20-03188-00	Latch, Spring Cabinet	2	
28	VG26-03189-00	Catch, Spring Cabinet Latch	2	
29	VG26-04482-00	Latch Bolt	2	
30	VG46-02654-00	Label, FBI Warning	1	
31	VG46-02653-00	Label, FCC	1	
32	VG44-02642-00	Label, Service Personnel Only	1	
33	VG83-03206-00	Coin Door, O/U, Blk W/Harness	1	
34	VG88-06871-00	Power Supply, Switching, 200W, W/Pwr Cord	1	
35	VG10-03811-00	Bracket, Ground Lug	1	
36	VG78-05265-00	Assy, Housing and Ferrite Bead, Round	5	
37	T250-04345-00	Harness, RGB Extension	1	
38	T250-04346-00	Harness, Fluorescent Fixture	1	
39	T250-04347-00	Harness, AC Monitor	1	
40	T250-04348-00	Harness, Main AC	1	
41	T250-04349-00	Harness, Speaker	1	
42	T250-04354-00	Harness, Ground, Control Panel	1	
43	T250-04473-00	Harness, Fluorescent Extension	1	
44	EZ50-07463-00	Harness, Control Panel, Player 1	1	
45	EZ50-07464-00	Harness, Control Panel, Player2	1	

ASSY, OVERALL (EZ01-07474-00)

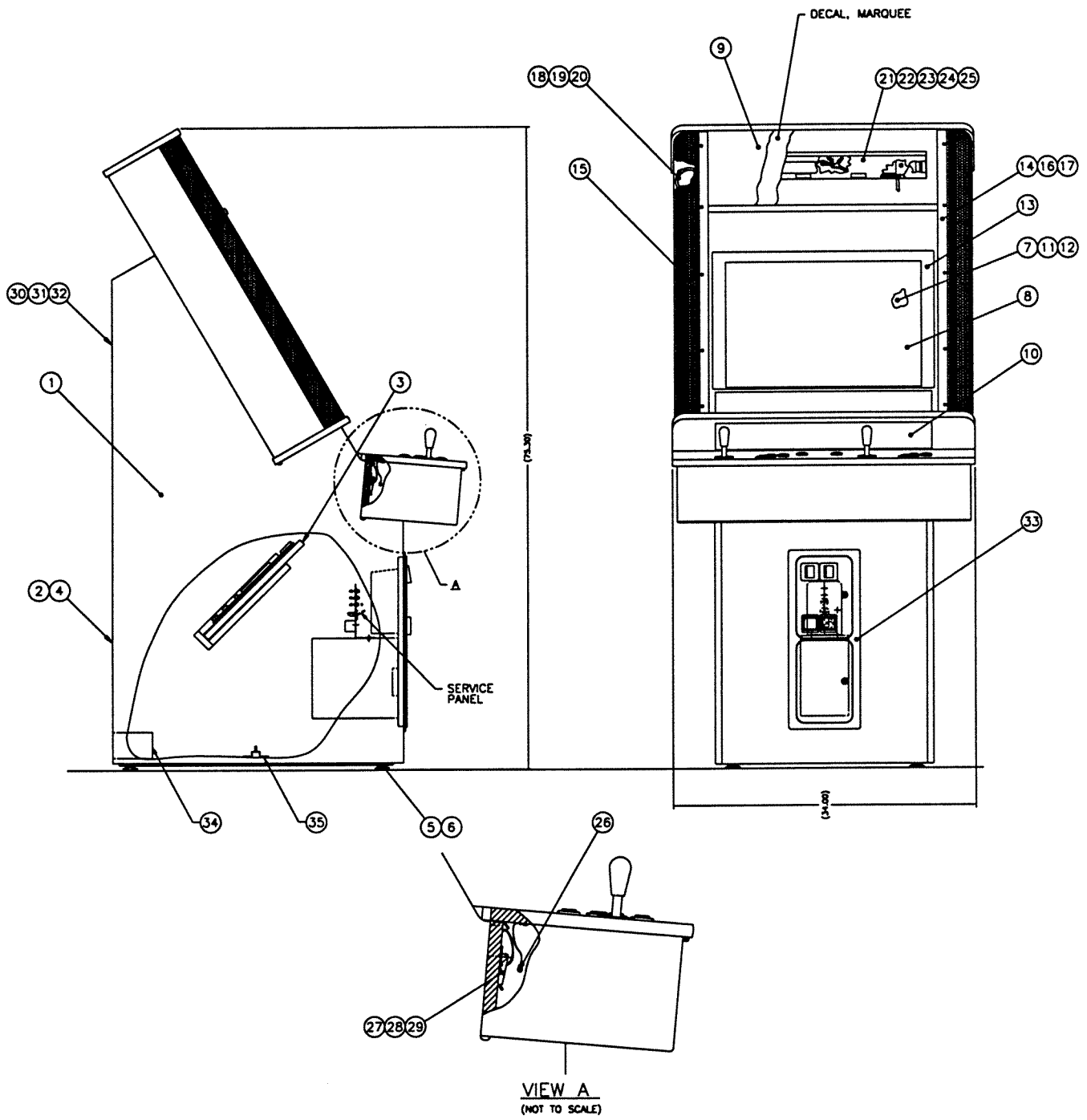

SUBASSEMBLY PARTS LIST, EHRGEIZ 27" VIDEO CABINET

NO.	PART NO.	DESCRIPTION	Q/G	NOTES
		ASSY, SERVICE PANEL	1	
1	VG83-02094-00	COIN COUNTER, 12VDC W/ INTERNAL DIODE (HA	1	
2	VG44-02702-01	LABEL, SERVICE PANEL "SERVICE"	1	
3	VG44-02702-00	LABEL, SERVICE PANEL "TEST"	1	
4	VG44-02702-02	LABEL, SERVICE PANEL "VOLUME"	2	
5	VG44-02702-05	LABEL, SERVICE PANEL "LEFT"	1	
6	VG44-02702-06	LABEL, SERVICE PANEL "RIGHT"	1	
7	MC10-03000-00	BRACKET, SERVICE PANEL	1	
8	GT53-02052-00	SWITCH, P/B SPST-NO 125VAC 0.5A black (TEST)	1	
9	VG53-00756-00	SWITCH, TOGGLE, SPST (SERVICE)	1	
10	VG75-00103-00	POT, VOLUME 100 OHM	2	
11	GT53-02038-00	KNOB, PHENOLIC BLK 1/8 SHAFT (VOL POT)	2	
12	VG20-02894-04	SCREW, PAN HD PHIL 4-40 X 1/4 SZ	2	
13	T250-04351-00	HARNESS, SERVICE PANEL	1	
		ASSY, EHRGEIZ PCB		
1	EZ03-07444-00	EHRGEIZ PCB SYSTEM 12	1	
2	EZ50-07465-00	Harness, JAMMA	1	
3	VG44-03213-00	Label, JAMMA Harness, Component Side	1	
4	VG44-03213-01	Label, JAMMA Harness, Solder Side	1	
5	VG05-06607-00	Mounting Feet, PCB w/screw	4	
		ASSY, Control Panel, EHRGEIZ		
1	VG10-07458-00	Control Panel	1	
2	VG95-07460-00	Cover, Control Panel	1	
3	VG20-04276-00	Screw, #8 x 3/4, SHT MTL, BTN HD TorxTmpr Proof	8	
4	VG20-02700-05	Nut, KEP, #10-24, SZ	8	
5	VG20-02864-05	Washer, Flat, #10, SZ	8	
6	VG80-04707-00	ASSY, BUTTON AND JOYSTICK	1	
7	VG80-03212-00	JOYSTICK, 4/8-WAY, SUPER BK	2	
8	VG80-06577-00	PUSHBUTTON W/MICROSW, RED	8	
9	VG80-06578-00	PUSHBUTTON W/MICROSW, YEL	2	
10	VG20-02700-05	Nut, Kep #10-24 SZ	8	
		MISC		
1	VG46-02655-00	Label, Serial No., Legend: "EHRGEIZ ","EZ01-07474	1	
2	VG46-02652-00	Label, UL, Model: "V-204-EZ","4A"	1	
3	EZ45-07472-00	Operator's Manual, Ehrgeiz	1	

DECAL LOCATION (DCLLOC)

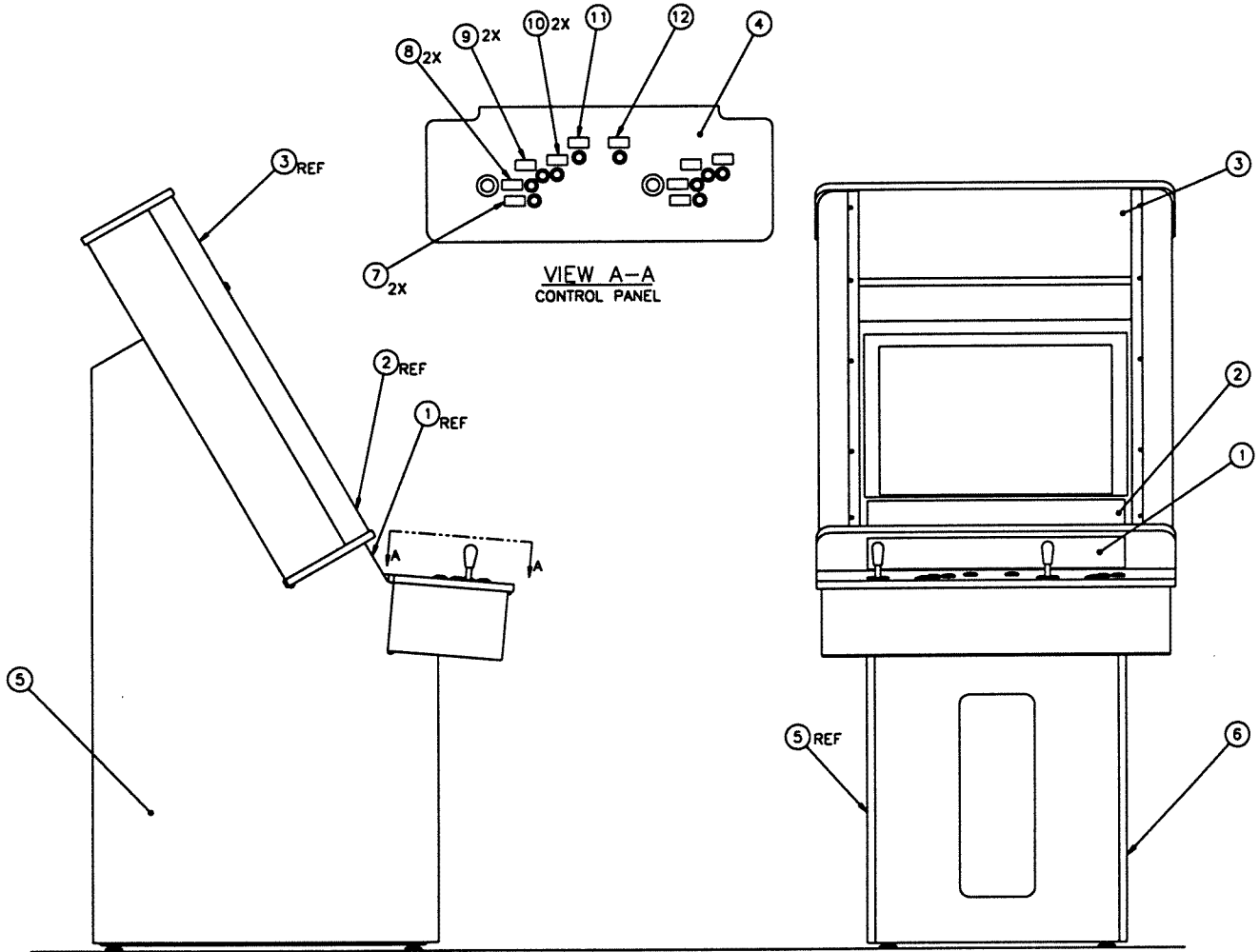

DECAL LOCATION, EHRGEIZ 27" CABINET

#	PART NO.	DESCRIPTION	QTY	NOTES
1	EZ40-07446-00	CARD, GAME INSTRUCTIONS	1	
2	EZ40-07447-00	CARD, MOVE LIST	1	
3	EZ40-07448-00	DECAL, MARQUEE	1	
4	EZ40-07459-00	DECAL, CONTROL PANEL (dedicated)	1	
5	EZ40-07455-00	DECAL, SIDE, LEFT	1	
6	EZ40-07516-00	DECAL, SIDE, RIGHT	1	
7	EZ40-07451-00	DECAL, GUARD LABEL	2	
8	EZ40-07452-00	DECAL, LOW LABEL	2	
9	EZ40-07453-00	DECAL, HIGH LABEL	2	
10	EZ40-07454-00	DECAL, SPECIAL/JUMP LABEL	2	
11	EZ40-07456-00	DECAL, PLAYER 1 LABEL	1	
12	EZ40-07457-00	DECAL, PLAYER 2 LABEL	1	

REV	DESCRIPTION	DATE	APPROVAL
3	BUTTON LAYOUT	2/20/98	

NOTES:
 1. APPLY 18AVG FOR THICK LINES AND 28AVG FOR THIN LINES
 2. (C) INDICATES RING TERMINAL
 3. LABELS ARE APPLIED TO BOTH SIDES OF 56 PIN CONNECTOR
 4. KEYS ARE APPLIED ON BOTH 56 AND 48 PIN CONNECTORS

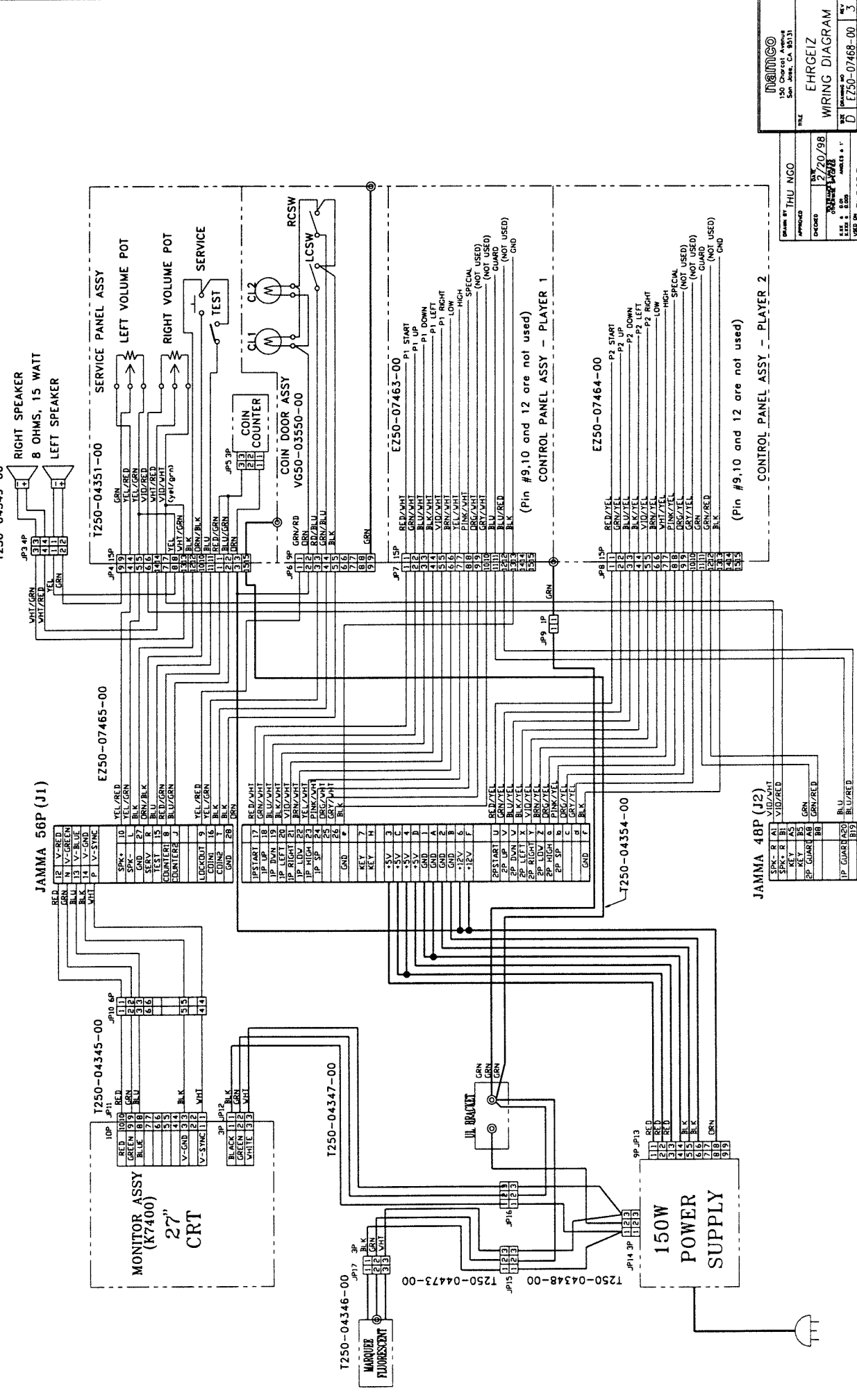

WARRANTY

Seller warrants that its printed circuit boards and parts thereon are free from defects in materials and workmanship under normal use and service for a period of ninety (90) days from the date of shipment. Seller warrants that its video displays (in games supplied with video displays) are free from defects in material and workmanship under normal use and service for a period of thirty (30) days from the date of shipment. None of the Seller's other products or parts thereof are warranted. Seller's sole liability shall be, at its option, to repair, replace, or credit Buyer's account for such products which are returned to Seller during said warranty period, provided:

- a) Seller is promptly notified in writing upon discovery by Buyer that said products are defective.
- b) Such products are returned prepaid to Seller's plant; and
- c) Seller's examination of said products discloses to Seller's satisfaction that such alleged defects existed and were not caused by accident, misuse, neglect, alteration, improper repair, improper installation, or improper testing.

In no event shall Seller be liable for loss of profits, loss of use, incidental or consequential damages.

Except for any express warranty set forth in a written contract between Seller and Buyer which contract supersedes the terms herein, this warranty is in lieu of all other warranties expressed or implied, including the implied warranties of merchantability and fitness for a particular purpose, and all other obligations or liabilities on the Seller's part, and it neither assumes nor authorizes any other person to assume for the Seller any other liabilities in connection with the sale of products by Seller.

Namco America Inc. distributors are independent, being privately owned and operated. In their judgment they may sell parts or accessories other than **Namco America Inc.** parts or accessories. **Namco America Inc.** cannot be responsible for the quality, suitability or safety of any non-**Namco America Inc.** part or any modification including labor which is performed by such distributor.

SERVICE

If you have questions regarding any **Namco America Inc.** product or require technical support:

Contact **Namco America Inc.** Customer Service at:

1 (800) 326-4263 or FAX (408) 232-3060

Hours: 7:00 am - 5:00 pm PDT

Parts and repair services for **Namco America Inc.** products are available through your distributor.

namcoAmerica Inc.

150 Charcot Ave.

San Jose, CA 95131

(408) 383-3900

FAX: (408) 383-0128

Technical Assistance (USA)

(800) 326-4263

Fax: (408) 232-3060

<http://www.namco.com>

Reorder Number EZ45-07472-00

REV. A